

Installation/Operating Instructions

220V Signature/Series E & V Electric Projection Screen

US Patent No.
5,341,241

These Installation/Operating Instructions are available in the official language of the country where you purchase the product. Please contact your distributor to request a copy.

Vous pourriez demander les instructions d'installation et d'opération traduites dans la langue officielle du pays où vous achetez le produit. Veuillez demander à votre distributeur.

Die Gebrauchsanweisung für Installation und Konstruktion sind in der offiziellen Sprache des Landes, indem Sie das Produkt gekauft haben, vorhanden. Fragen Sie die jeweilige Verkaufs-Abteilung.

⚠ Caution

- ① Read instructions through completely before proceeding. Follow instructions carefully. Installation contrary to instructions invalidates warranty.
- ② Pick up screen case from **ends only**. Picking case up at other points **will damage case and may damage fabric**.
- ③ To insure a safe installation, the **entire weight** of the unit **MUST BE** supported by the end-plates.
- ④ Entire bottom of screen case should be unobstructed to permit proper operation of automatic trap door, and access to bottom panel for making electrical connections or servicing.
- ⑤ Screen should be installed level (using a carpenter's level).
- ⑥ Nothing should be fastened to screen dowel, viewing surface or automatic trap door.
- ⑦ Operating switch(es) packed separately in screen carton. Do not discard with packing material.
- ⑧ Screen operates on 220V AC, 50 Hz. current.

NOTE: Screen has been thoroughly inspected and tested at factory and found to be operating properly prior to shipment.

These instructions are meant as a guide only. They do not imply any responsibility on the part of Draper, Inc. for improper installation or faulty workmanship at the jobsite.

Hanging Screen

When locating viewing surface and checking clearance for screen's operation, remember that the surface is centered in case. Screen is normally recessed above ceiling and may be installed in a variety of ways. See details on back of this sheet. Regardless of mounting method used, the following points apply:

- ① **Keep case level when lifting and mounting.** Pick up screen case from **ends only**. Picking case up at other points **will damage case & may damage fabric**.
- ② Screen should be positively and securely supported so that vibration or even abusive pulling on viewing surface will not weaken installation.
- ③ Installer must insure that fasteners used are of adequate strength and suitable for the mounting surface chosen.
- ④ Entire bottom of case must be readily accessible after installation.
- ⑤ The hinge that connects bottom panel and automatic trap door of screen must be permitted to operate freely. Front and back of case must be straight—not forced to warp or bow. Hinges must be free from mastic or paint buildup, and doors must be unobstructed by ceiling tiles.
- ⑥ Do not use screen case to support adjacent sections of ceiling.
- ⑦ If trim pieces must be attached to case, do not permit screws to protrude more than 6.35mm thru 3.2mm wall of case. Do **not** attach trim pieces with nails.
- ⑧ If case is painted, slots on bottom of case should be shielded to protect viewing surface from paint splatters or overspray.
- ⑨ Do not seal unit in ceiling until electrical connections have been made and screen has been operated successfully.

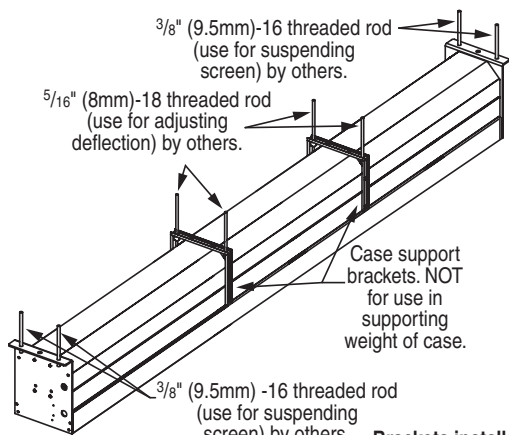

Brackets installed with rivets at factory.
Bracket spacing:

- Small Case Construction /E or /V
- Case length <95"—no brackets required
- Case length >95"—1 bracket centered
- Large Case Construction /E or /V
- 2 brackets equally spaced

DRAPER®

411 S. Pearl St., Spiceland, IN 47385 USA ■ +1 765-987-7999

www.draperinc.com ■ fax +1 765-987-1689

Copyright © 2013 Draper Inc. Form Signature220V_Inst13

Printed in U.S.A.

Electrical Connections

Screen operates on 220V AC, 50 Hz., 1 ph. current. Junction box is located just above the access plate at left end of screen. Access plate is held closed with flathead screws and may be opened with a Phillips screwdriver. **Automatic trap door does not need to be opened to make field connections.** Junction box contains pigtail leads and grounding screws, per wiring diagram on reverse. Screen is shipped with internal wiring complete and control switch(es) fully boxed. Wire connecting screen to switch(es) and switch(es) to power supply should be furnished by installer. Connections should be made in accordance with attached wiring diagram, and wiring should comply with National and local electrical codes. **All operating switches should be "OFF" before power is connected.**

Operation

⚠ **CAUTION—Important Instructions—Signature/Series V—**The shipping support brackets must be removed from each end of dowel during initial operation before screen is operated in UP direction. After screen is installed, run viewing



surface **DOWN** to access screws that hold brackets to dowel. Loosen hex head screw, remove bracket and retighten screw at each end of dowel. Signature/Series E—The protective paper wrapping around the viewing surface must be removed before the screen is operated in down direction. Cycle viewing surface down and up several times to confirm satisfactory operation. If viewing surface or trap door do not operate properly, turn power off and free trap door and/or check electrical connections.

220V Single Station Control—3-position UP-OFF-DOWN switch permits operation to be stopped at any point. Factory set limit switches automatically stop screen when fully down or fully up.

220V Multiple Station Control (Not CE Approved)—Switches are similar in appearance to Single Station Control. Screen stops when switch is released and may be restarted in either direction. Factory set limit switches stop screen automatically when fully down or fully up.

24V Control—Three-button UP-STOP-DOWN switches stop at any point desired, operate in any sequence. Factory set limit switches automatically stop screen when fully down or fully up. Wireless controls—whether infrared or radio frequency—interface with low voltage control box.

Key Operated Switching (Not CE Approved)—Two kinds of key-operated switches are optionally available with this unit. ① The key-operated power supply switch controls power to the screen and switches. When it is "off", the switches will not operate screen. Key may be removed from the switch in "on" or "off" position.

② A three-position key switch permits the screen to be operated directly by key. In this case, the screen's operator must have a key.

RS232/Ethernet—Serial communication and network communication optionally available with wall switches, RF or IR remote.

Adjustments

Please Note: Screen limits are factory set for optimum performance of the screen. A procedure is outlined below for minor tweaks, but any adjustment of these limits may negatively affect the flatness of the screen surface and could also void the warranty. Please check with Draper prior to resetting screen limits.

⚠ **CAUTION: Always be prepared to shut screen off manually when new adjustment is being tested. Screen may be severely damaged if viewing surface is allowed to run too far up or too far down.**

⚠ **CAUTION: Be sure all switches are in "off" position before adjusting limit switches.**

Adjusting "Fully Up" Position—"Up" stopping position may be adjusted by turning the yellow limit switch adjustment socket. The yellow socket is located on left end of screen roller and is accessible to a screwdriver/Allen wrench (4mm or 5/32"). Turning the socket counterclockwise will allow the viewing surface to retract further into the case. Turning it clockwise will cause the surface to stop further out of the case. One full revolution of the socket will alter the stopping position of the viewing surface by approximately 3.8 cm.

Adjusting "Fully Down" Position—"Down" stopping position may be adjusted by turning the white limit switch adjustment socket. The white socket is located on the left end of screen roller and is accessible to a small flat screwdriver/Allen wrench (4mm or 5/32"). Turning the socket counterclockwise will allow the viewing surface to run farther down. Turning it clockwise will shorten the viewing surface, causing it to stop in a less extended position. **At no time should viewing surface be unrolled enough to expose any part of the screen roller.**

Please note: See page 2 for information on adjusting Tab-Tensioning cables on Signature/Series V screens.

If you encounter any difficulties installing or servicing your Signature screen, call your dealer or Draper, Inc. Spiceland, Indiana, U.S.A., (765) 987-7999, FAX (765) 987-1689.

Case Dimensions and Methods of Installation

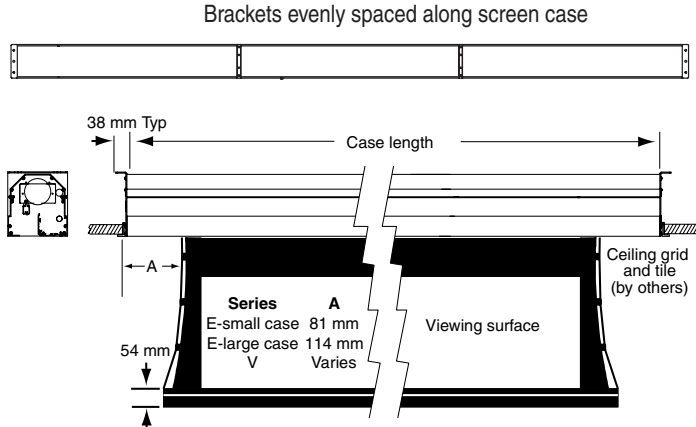

NOTE: Viewing surface shown is Series V with tab tensioning. Series E, without tab tensioning, is also available.

Tab-Tensioning Cable Adjustment

Draper's Tab-Tensioning System is factory-set, and under normal circumstances will not require field adjustment. If, however, you notice wrinkles, waves, or other indications that the tensioning cables need to be adjusted, follow the procedure below.

- 1 Determine which side requires adjustment.
- 2 Secure dowel with one hand.
- 3 **Caution: Do not touch or bend surface.** Using Phillips-head screwdriver, depress spring-loaded adjustment screw (see Fig. 1) and slowly turn clockwise to tighten tension, or counterclockwise to loosen tension. The screw adjusts in 1/4 turn increments. Adjust only **one increment** (1/4 turn).
- 4 If problem is not corrected, leave screen in position for 24 hours to allow surface material to stretch into position.
- 5 If problem still is not corrected, repeat steps 2 and 3.

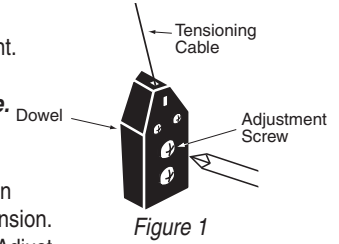

Small Signature Case

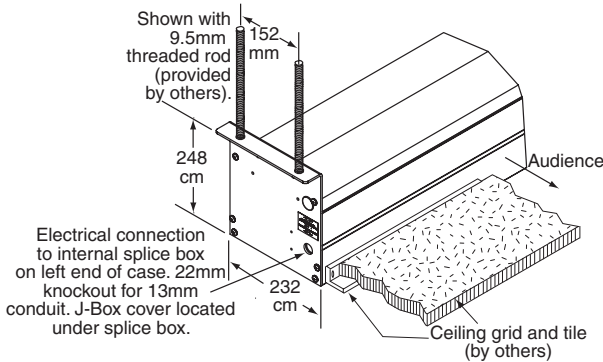

Large Signature Case

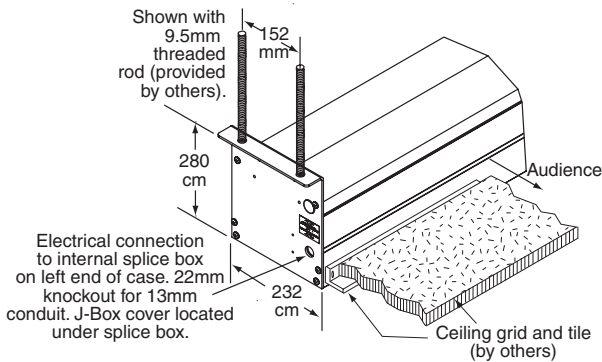

SCREEN SIZE	CASE SIZE
Total Drop < 396 cm or viewing width < 366 cm	Small
Total Drop > 396 cm or viewing width > 366 cm	Large

MC1

See separate Serial Communication-RS232 Instruction sheet for enabling RS232 with the MC1.

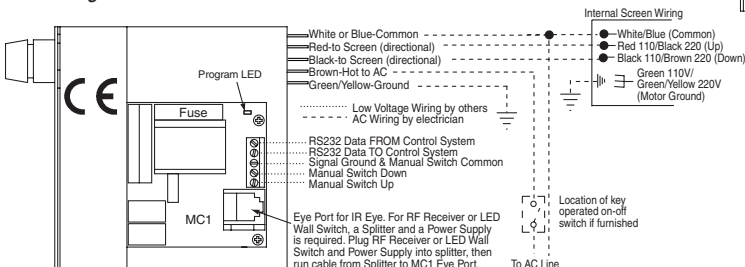

Wiring Diagrams

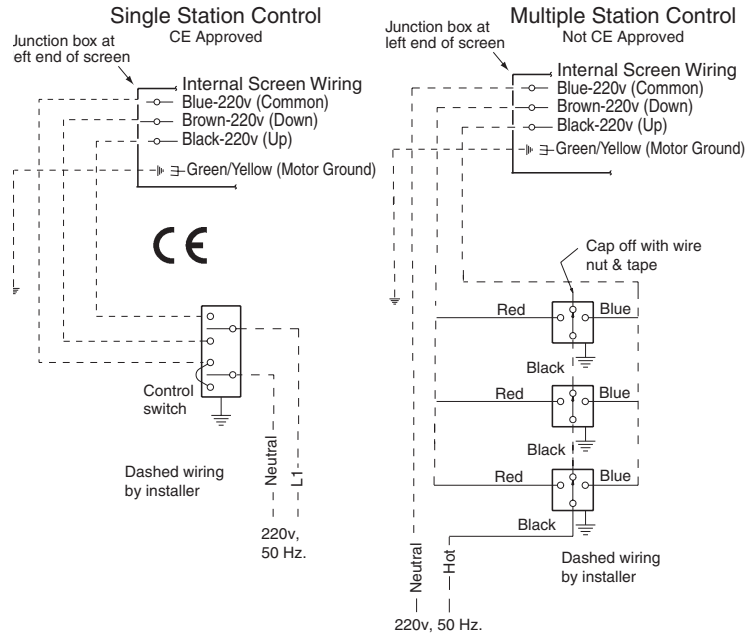

Low Voltage & Wireless Control

