

Installation Instructions

Holo View Holographic Rear Projection Screen by Draper

Receiving

Holo View rear projection screens are shipped in durable wooden crates and are packaged in accordance with accepted packaging standards for this type of material. However, occasionally a shipment will incur freight damage due to particularly rough handling in transit. Therefore, your Holo View screens should be inspected immediately upon delivery.

It is the customer's responsibility to open the crate immediately, inspect and note any freight damage on the carrier's receiving bill of lading, while the Driver is present. If concealed damage is discovered, it is your responsibility to notify the delivering carrier immediately and file your own claim.

The damaged product must be held at the original shipping address and in its original crate. An inspection by a representative of the delivering carrier must be made within 14 days following receipt of shipment. Many carriers do not honor claims for concealed damage unless they are notified within three days. Neither we nor our dealer can accept responsibility for claims arising from merchandise damaged in shipment unless the above procedure is followed. After inspection has been made, the shipping crate should be sealed until installation.

NOTE: Holo-View rear projection screens should be handled and stored upright at all times.

Unpacking

Use extreme care in unpacking to avoid scratching the surface. Do not use knives to remove wrapping. Use soft cotton gloves, a soft cloth or tissue paper as a hand pad.

Before removing wrapping, compare the size of the finished aperture with the Holo View panel. Holo View screens should not be cut or altered in the field. Any alteration of a Holo View screen after it leaves our plant automatically voids the product warranty.

Installation

The Holo View may be installed with either side facing the projection source.

To obtain optimum image quality, adhere to the following guidelines:

- The projector does not need to be mounted on-axis; however, care must be taken to ensure that the light path will not be pointing toward the eyes of the intended audience.
- Refer to Holo View specifications for optimum projected throw distance.

NOTE: The Holo View must be mounted securely. Draper recommends screens 90" diagonal and above be framed, preferably with Draper's Large Screen Mounting Frame at the top and aluminum grip strip at the bottom. Make sure all other aspects of construction have been completed before Holo View rear projection screen installation, including painting and cleanup. If additional finish work must be done after installation, cover screen with clear polyethylene sheeting until all work has been completed. (In a facility that is still under construction, more protection is warranted, such as a masonite or homocel covering. Hard coverings must not be allowed to contact the screen's surface directly.)

Cleanup

Dust may be removed from the Holo View surface with a soft clean cloth or by vacuum cleaning with a soft brush. For removal of stains use a mild soap and distilled water solution. Wring free of excess moisture before applying, rinse and blot dry. Do not rub. Do not use solvents of any type without Draper's recommendation.

Framing Details

Holo View screens come with frame for suspension pre-mounted. Other framing systems are available. Aluminum, wood and steel are all suitable materials. It is essential that any Holo View rear projection screen be fully isolated from load bearing, and a minimum of ¼" clearance must be allowed for insertion. Any Holo View 90" diagonal or larger should be framed. Consult a qualified glazing specialist when planning any framed field installation. See Holo View specifications for details on available framing systems.

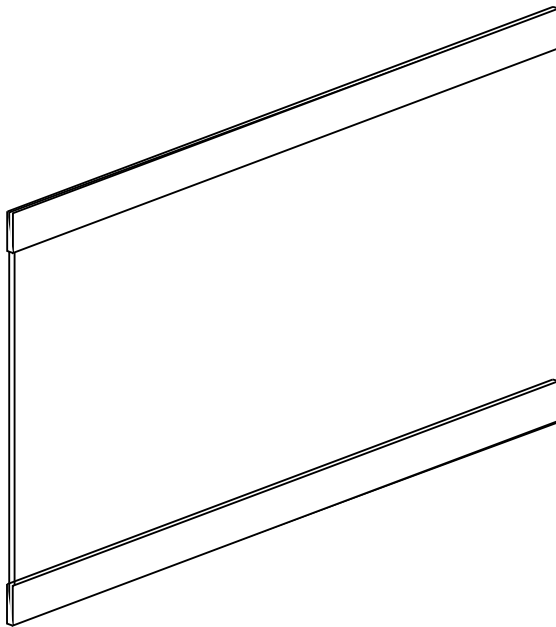

**Standard Mounting Detail
(Through 84" diagonal)**

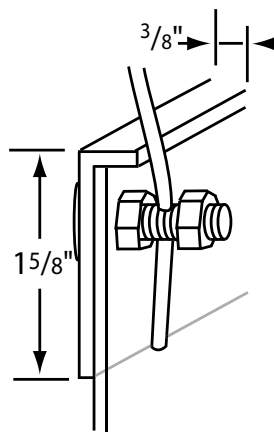

**Large Screen Mounting Detail
(90" diagonal and Larger)**

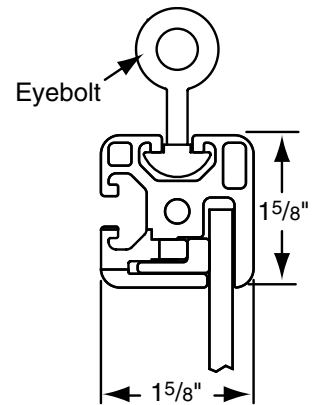

Note:

Screens 90" diagonal and larger come with Large Screen Mounting Frame at top of screen and grip strip at bottom

DRAPER

411 S. Pearl St., Spiceland, IN 47385 USA ■ 765-987-7999 ■ fax 765-987-7142

e-mail draper@draperinc.com ■ www.draperinc.com

Copyright © 2004 Draper Inc.

Form Holo-View_Inst04

Printed in U.S.A.

If you encounter any difficulties installing or servicing your Holo-View holographic rear projection screen, call your dealer or Draper, Inc., Spiceland, Indiana, (765) 987-7999, fax (765) 987-7142, or e-mail draper@draperinc.com.