

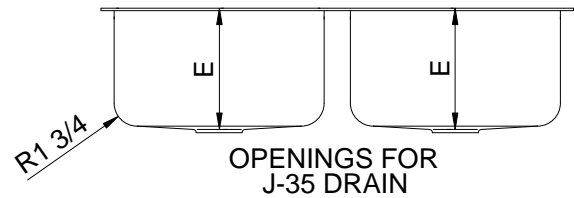

UDX-SERIES - A - 18 GA.
UDXD-SERIES - A - 18 GA.
UNDERMOUNT GROUP
DOUBLE COMPARTMENT - UNDERMOUNT

SUBMITTAL DATA

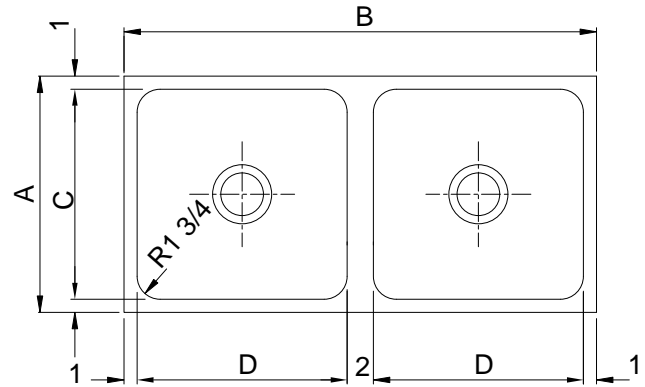
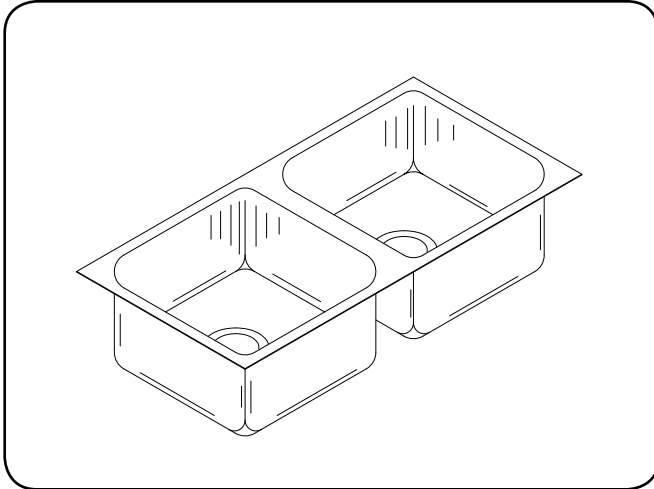

SPECIFICATION

Seamless die-drawn construction of 18 ga. type 304, 18-8 stainless steel. Interior and top surfaces polished to a non-porous Hand-Blended Just Finish with highlighted bowl rim. Fully coated underside insulates for sound, and reduces condensation. Conforms to ASME/ANSI A112.19.3M. Furnished with undermount clips less fasteners. Drain punch #35 for Just J-35 unless otherwise specified.

| MODEL NO. | A | B | C | D | E |
|-------------|----|----|----|----|--------|
| UDX-1632-A | 16 | 32 | 14 | 14 | 10-1/2 |
| UDX-1832-A | 18 | 32 | 16 | 14 | 10-1/2 |
| UDX-1836-A | 18 | 36 | 16 | 16 | 10-1/2 |
| UDX-1842-A | 18 | 42 | 16 | 19 | 10-1/2 |
| UDX-1848-A | 18 | 48 | 16 | 22 | 10-1/2 |
| UDXD-1832-A | 18 | 32 | 16 | 14 | 12 |
| UDXD-1842-A | 18 | 42 | 16 | 19 | 12 |



JUST MFG. COMPANY CONTINUES TO MAKE QUALITY AND FUNCTIONALITY A MARK OF THE JUST PRODUCT LINE. TO DO SO REQUIRES THAT WE RESERVE THE RIGHT TO CHANGE PRODUCT INFORMATION WITHOUT NOTICE. DIMENSIONS MAY VARY AND ARE SUBJECT TO CHANGE WITHOUT NOTICE. NO RESPONSIBILITY IS ASSUMED FOR USE OF SUPERCEDED OR VOIDED DATA. FOR THE MOST CURRENT AND ACCURATE INFORMATION REGARDING THE COMPLETE LINE OF JUST SINKS, FAUCETS AND DRAINS, CLICK ON THE **SPEC LINE DRAWINGS** LINK ON OUR WEB SITE AT www.justmfg.com

APPROVED FOR MANUFACTURING

MODEL NO.: _____ QTY: _____

JOB NAME: _____

TAG/ITEM: _____

CUSTOMER: _____

SIGNATURE: _____

JUST MANUFACTURING COMPANY

9233 KING STREET . FRANKLIN PARK . ILLINOIS . 60131-2111

PH: 847-678-5150 . FAX: 847-678-6817 . E-MAIL: custserv@justmfg.com . www.justmfg.com