

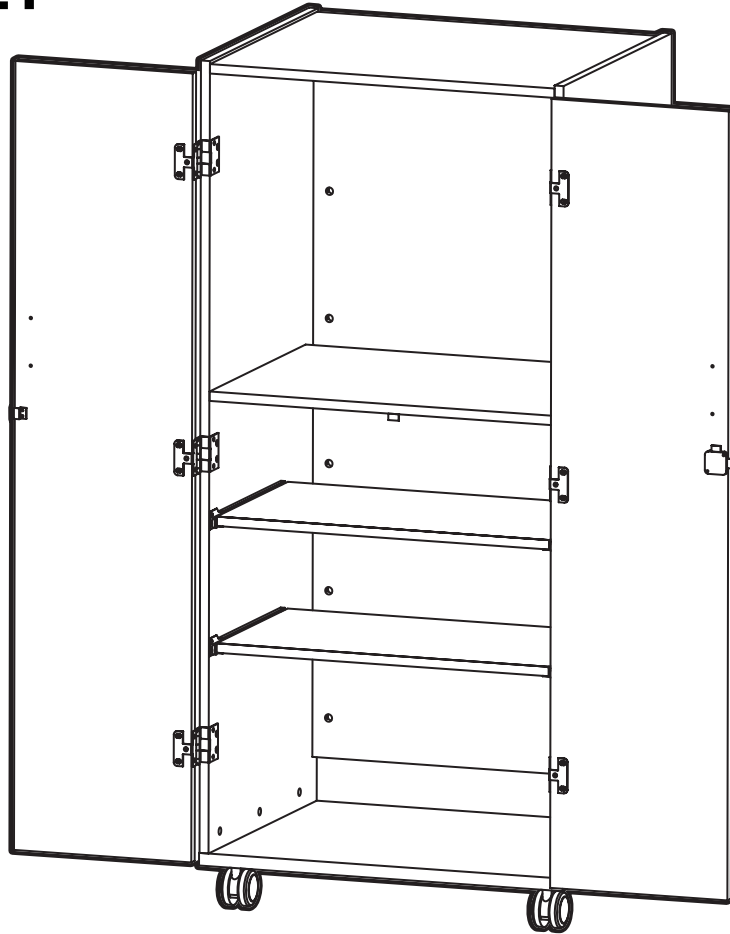

VC-2

VIDEO CABINET



IMPORTANT!

Assembly may require the assistance of another person.

Before you begin assembly:

READ THE DIRECTIONS all the way through one time. This will speed up the process and help you understand the sequence of steps.

COUNT THE PARTS AND HARDWARE before assembly. This ensures you have received all necessary parts before you begin.

TOOLS: You may need a Phillips head screwdriver, a medium slotted screwdriver or a plastic mallet. To protect your new furniture from damage during assembly, it is recommended to work on a carpeted surface.

In the event any parts are missing from this package, send your name, address, telephone number, and a description of the missing part(s) to: **PARTS, Box 1420, Missoula, MT 59806** or call: **1-800-769-5693** or **FAX 1-800-445-5281**.

CAUTION: On assemblies requiring glue, make sure the unit is assembled correctly before gluing. Once this unit is assembled with glue, the manufacturer will not be responsible for damaged parts. Keep a damp cloth or sponge handy to wipe off excess glue.

To care for this furniture, simply wipe with a cloth dampened with glass cleaner containing ammonia-D.

PARTS DIAGRAM

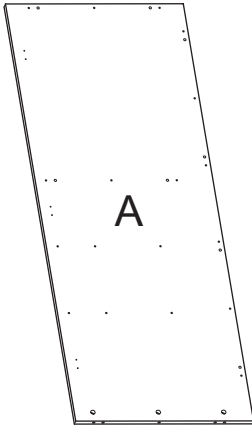

Left Side	05871641	1 ea.
-----------	----------	-------

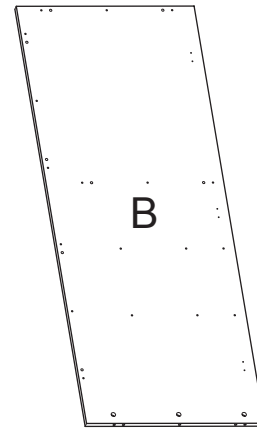

Right Side	05871641	1 ea.
------------	----------	-------

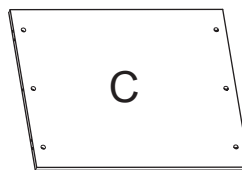

Top	05871601	1 ea.
-----	----------	-------

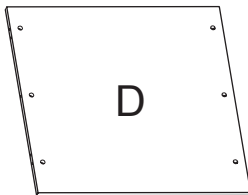

Upper & Lower Back	05871660	2 ea.
--------------------	----------	-------



Monitor Shelf	05871621	1 ea.
---------------	----------	-------



Adjustable Shelf	05871624	2 ea.
------------------	----------	-------



Bottom	05871611	1 ea.
--------	----------	-------

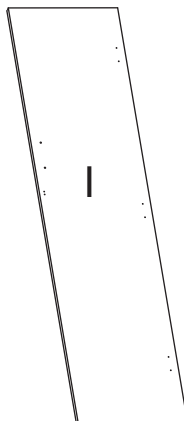

Left Door	05871673	1 ea.
-----------	----------	-------

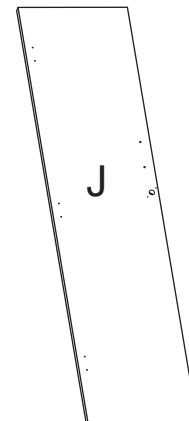

Right Door	05871673	1 ea.
------------	----------	-------

PARTS DIAGRAM



H1	Minifix Cam	909810	30 ea.
----	-------------	--------	--------



H2	Wood Dowel	195000	20 ea.
----	------------	--------	--------



H3	Minifix Bolt	909834	30 ea.
----	--------------	--------	--------

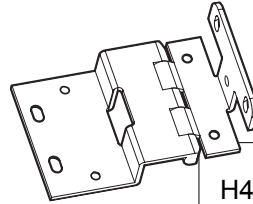

H4	Hinge	H0590	6 ea.
----	-------	-------	-------



H5	Varianta screws	988060	12 ea.
----	-----------------	--------	--------

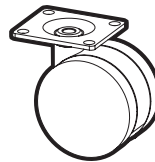

H8	Plate Caster	402640	4 ea.
----	--------------	--------	-------

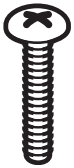

H11	1" Machine Screw	901314	4 ea.
-----	------------------	--------	-------



H9	#14 x 3/4" Panhead Screws	901241	16 ea.
----	---------------------------	--------	--------



H14	#6 x 5/8" Panhead Screws	901216	8 ea.
-----	--------------------------	--------	-------



H12	Door Pull	400800	2 ea.
-----	-----------	--------	-------



H15	#8 x 5/8" Flathead Screws	H2040	54 ea.
-----	---------------------------	-------	--------

LOCKSET 250-HP

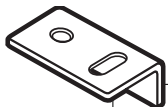

H6	Catch Plate	52340	1 ea.
----	-------------	-------	-------



H7	#8 x 5/8" Panhead Screws	988056	4 ea.
----	--------------------------	--------	-------

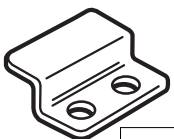

H10	Stop Plate	452330	1 ea.
-----	------------	--------	-------

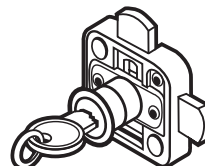

H13	Lock & Key Set	452310 452320 452350	1 ea.
-----	----------------	----------------------------	-------

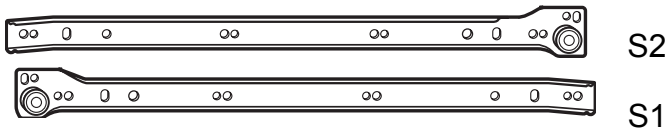

16" Side Channel (left & right)	490260	2 pr.
------------------------------------	--------	-------

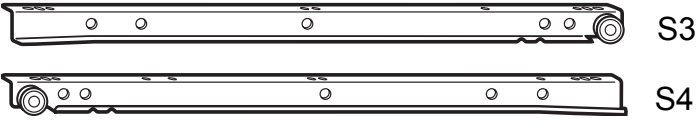

16" Shelf Slide (left & right)	490260	2 pr.
-----------------------------------	--------	-------

Using the Minifix System:

Insert the Minifix Cams into the appropriate holes with the arrow facing outwards as shown.

When screwing post into hole, **Do Not** over tighten. Screw post down until bottom face of post flange just touches board surface.

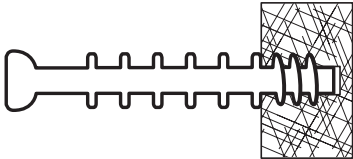

Using the #2 Phillips screwdriver, rotate the Cam Devices a half turn clockwise until snug.

To disassemble, turn the Cam Devices counter-clockwise and remove panels.

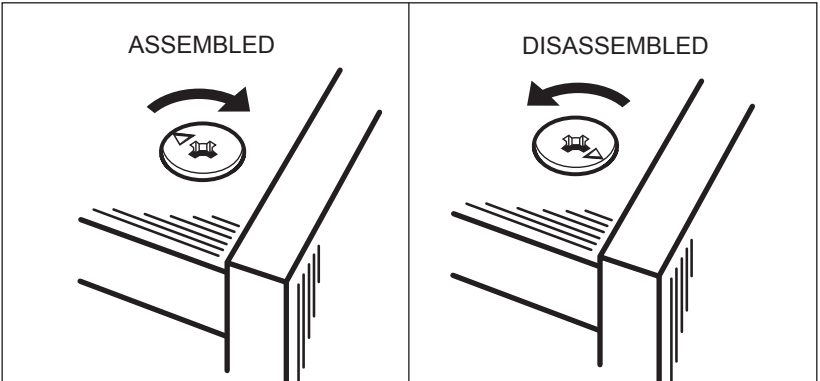
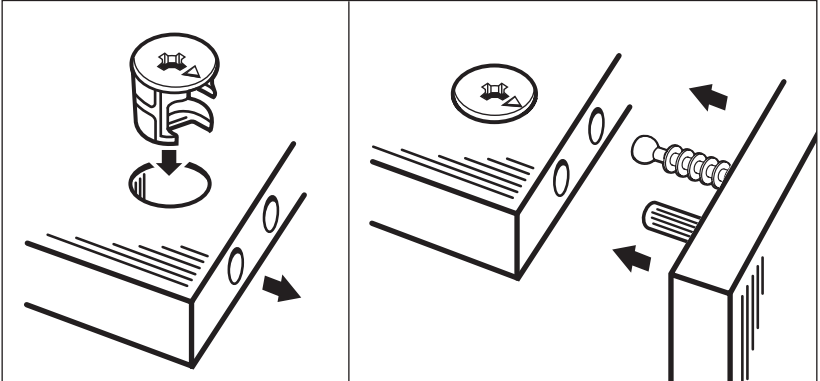

#1

Place the Left Side (A) and Right Side (B) on a clean, carpeted surface with the pre-drilled holes facing up. Insert three Minifix Cams (H1) into each Side with the arrows of the cams facing out.

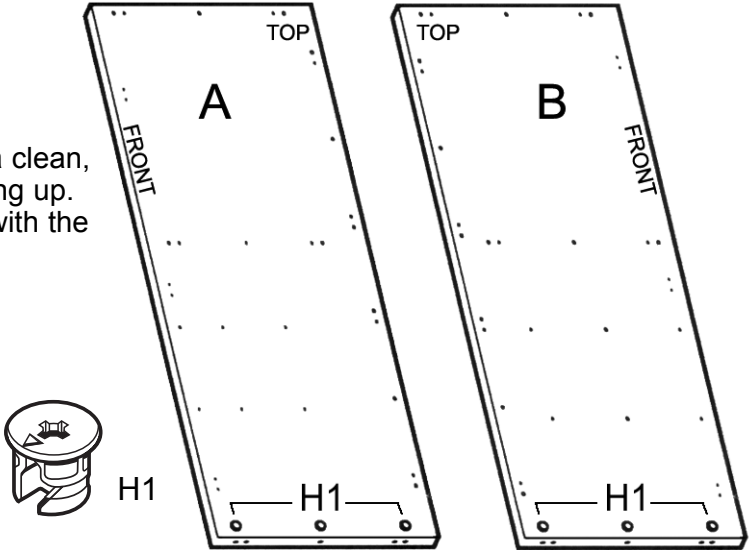

#2

Insert eight Dowels (H2) into the Left Side (A) and Right Side (B) where indicated.

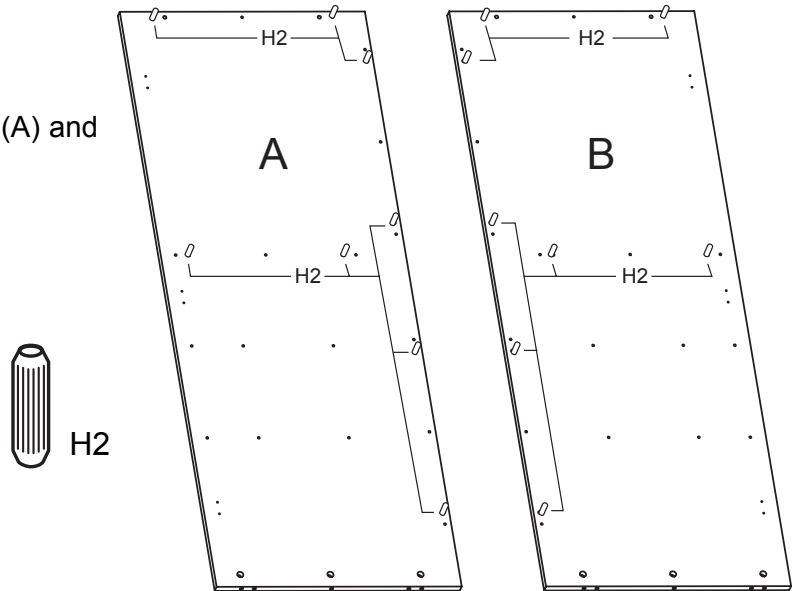

#3

Screw twelve Minifix Bolts (H3) into the Left Side (A) and Right Side (B) where indicated.

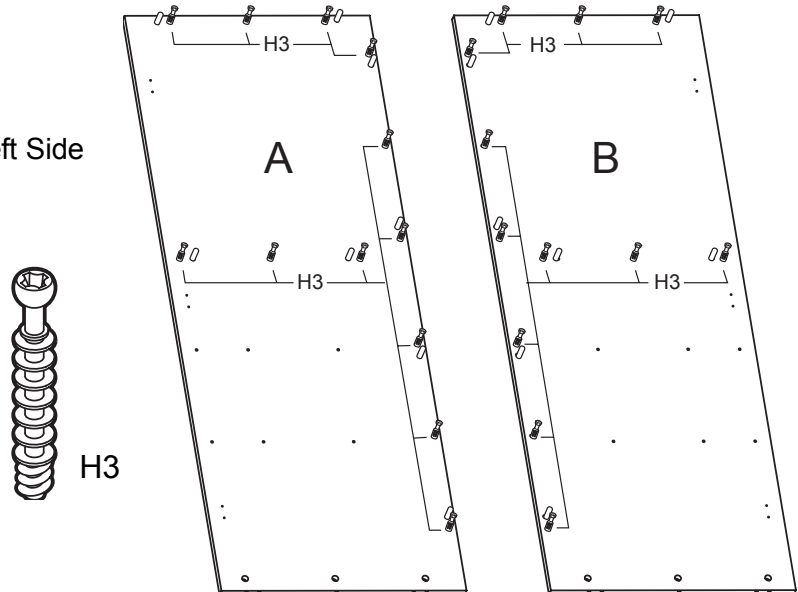

#4

With a screwdriver, attach the Hinges (H4) to the Left Side (A) using the #8 x 5/8" Flathead Screws (H15) in the pre-drilled holes. The screws must be centered in the slots of the Hinges as shown.

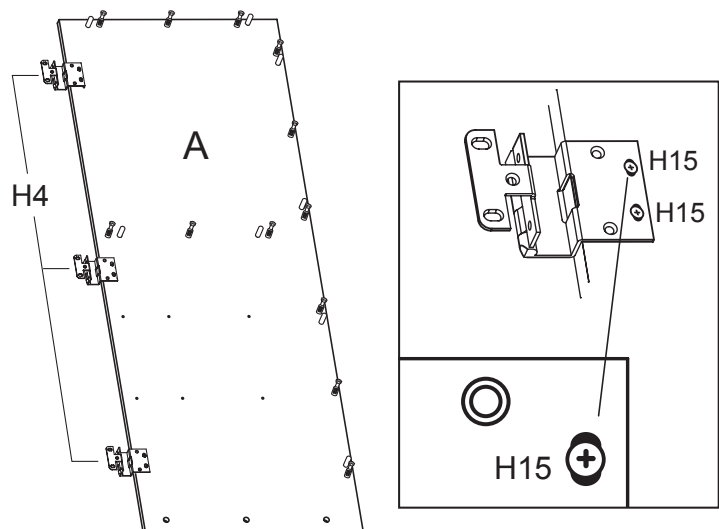

#5

With a screwdriver, attach the Hinges (H4) to the Right Side (B) using the #8 x 5/8" Flathead Screws (H15) in the pre-drilled holes. The screws must be centered in the slots of the Hinges as shown.

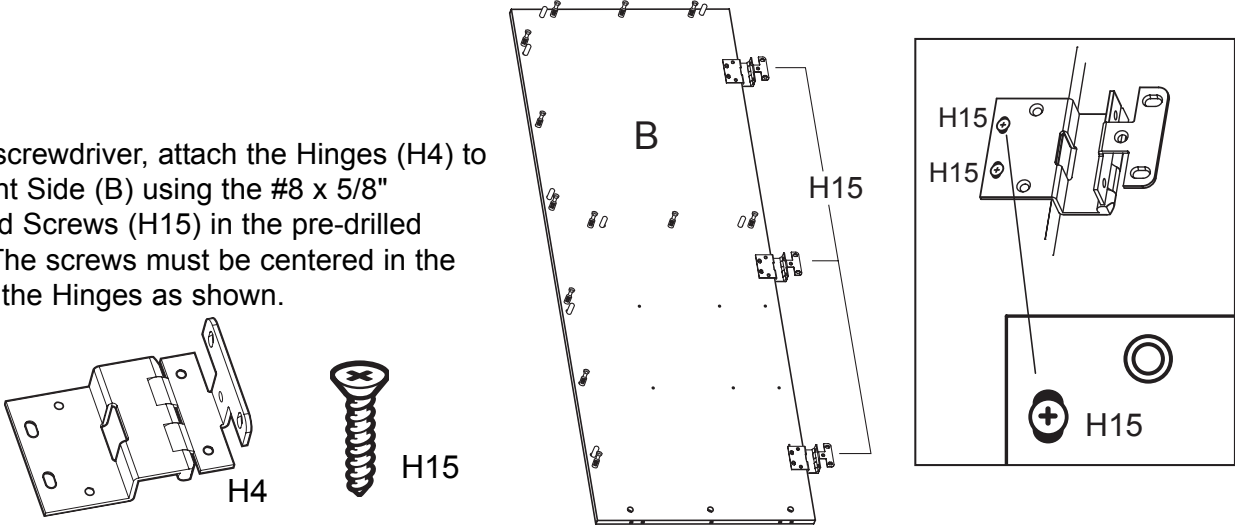

#6

Attach the two left Slide Channels (S1) to the Left Side (A) using six Varianta Screws (H5) into the pre-drilled holes where indicated.

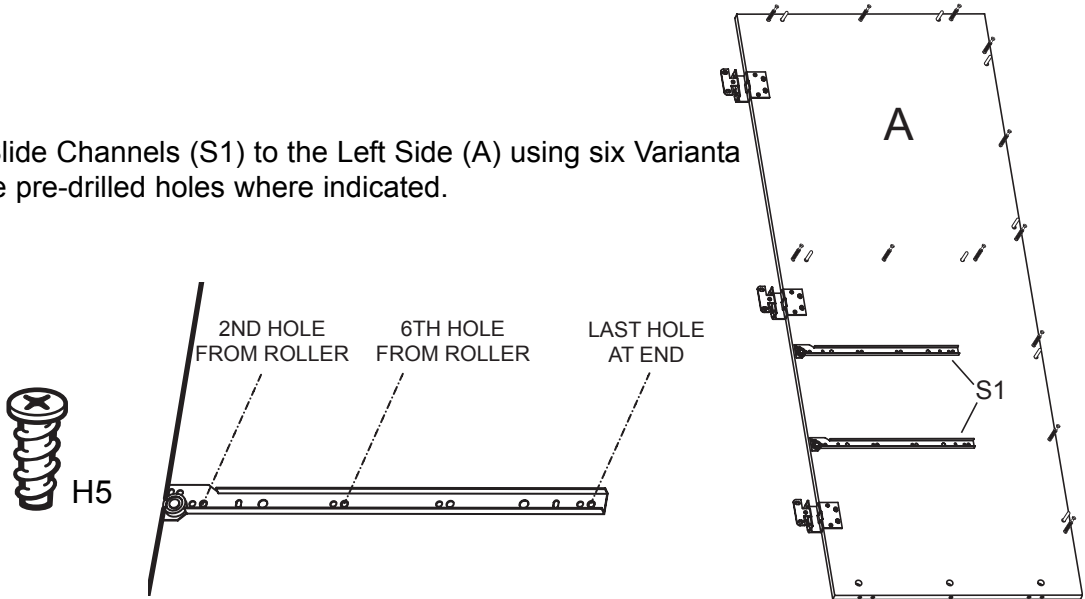

#7

Attach two right Slide Channels (S2) to the Right Side (B) using six Varianta Screws (H5) into the pre-drilled holes where indicated.

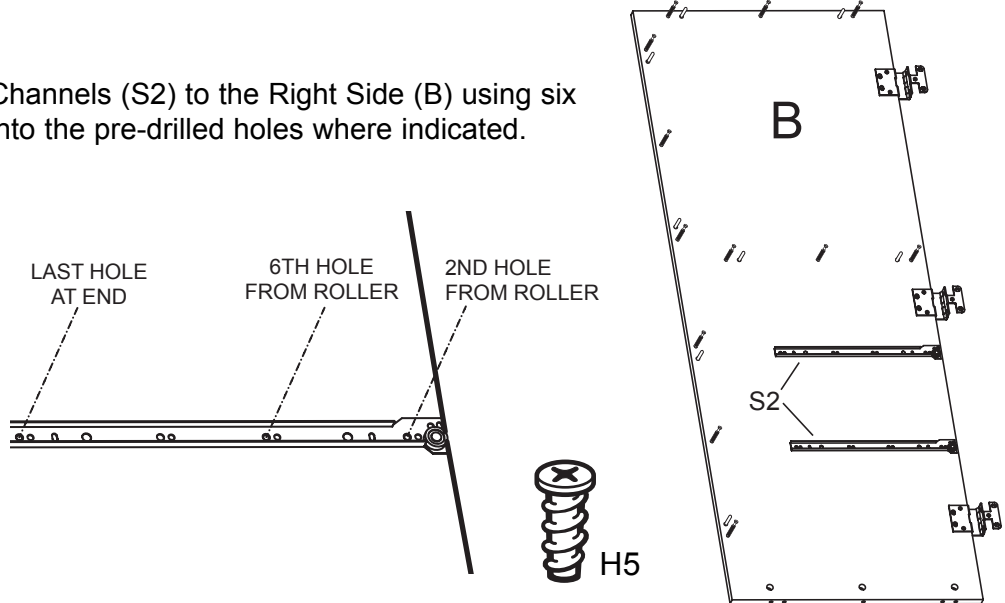

#8

Insert four Dowels (H2) into the Bottom (E) where indicated.



H2

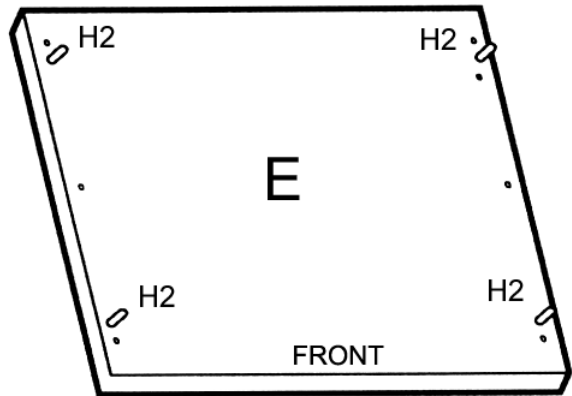

#9

Screw six Minifix bolts (H3) into the Bottom (E) where indicated.



H3

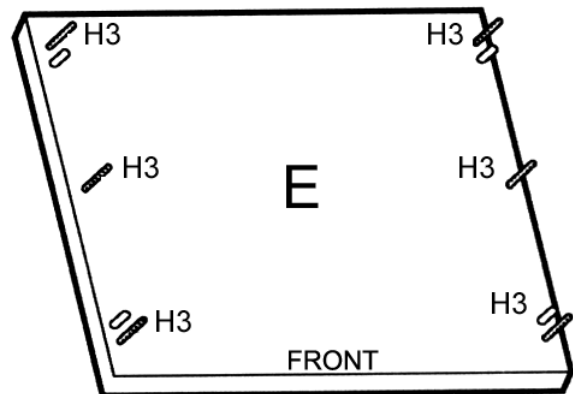

#10

Insert six Minifix Cams (H1) into the Top (C), Upper Back (D), and Lower Back (F) with the arrows of the cams facing out.



H1

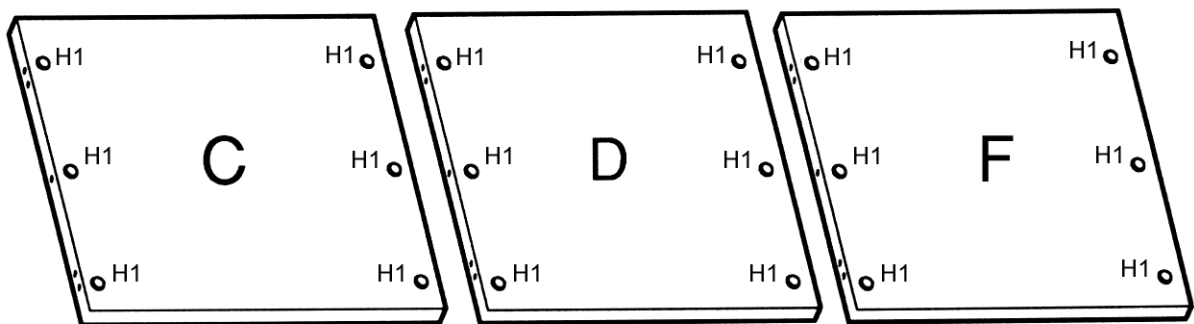

#11

Insert six Minifix Cams (H1) into the Monitor Shelf (G) with the arrows of the cams facing out.

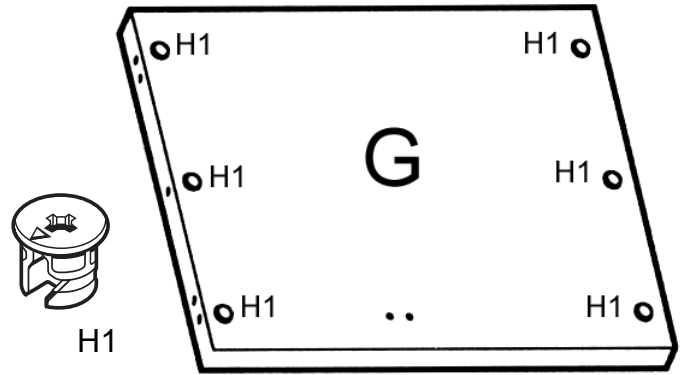

#12

Attach a Catch Plate (H6) to the Monitor Shelf (G) as shown using two #8x5/8" Panhead Screws (H7).

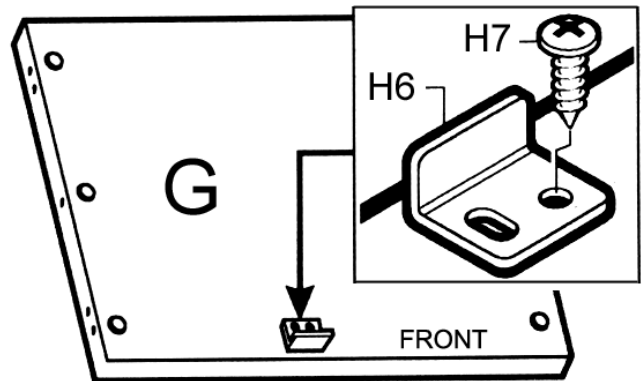

#13

With the aid of another person, position the cams of the Top (C) onto the bolts and dowels of the Left Side (A) as shown. Turn the arrows of the cams (H1) clockwise to secure.

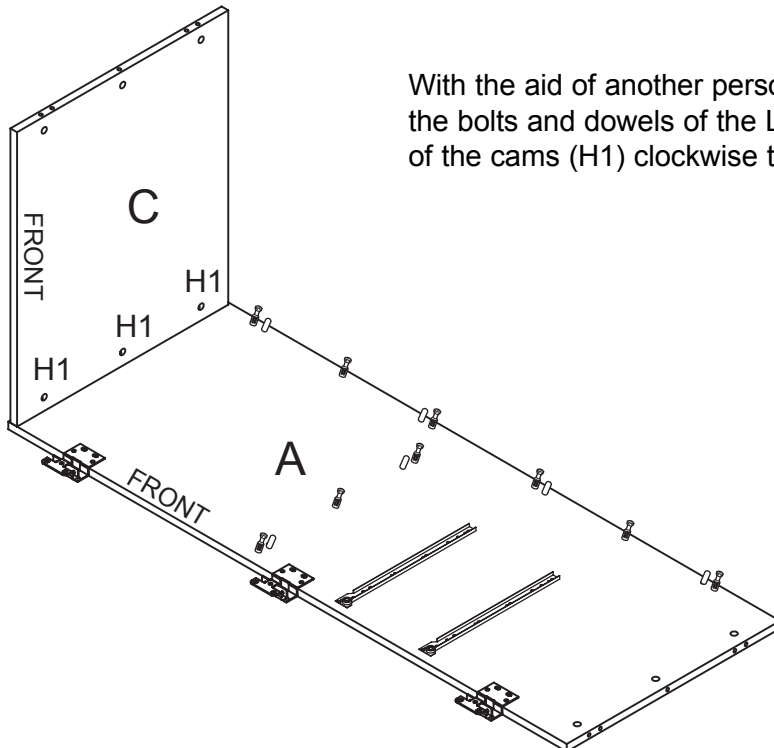

#14

Position the Upper Back (D) onto the Left Side (A) as shown and turn the arrows of the cams (H1) clockwise to secure.

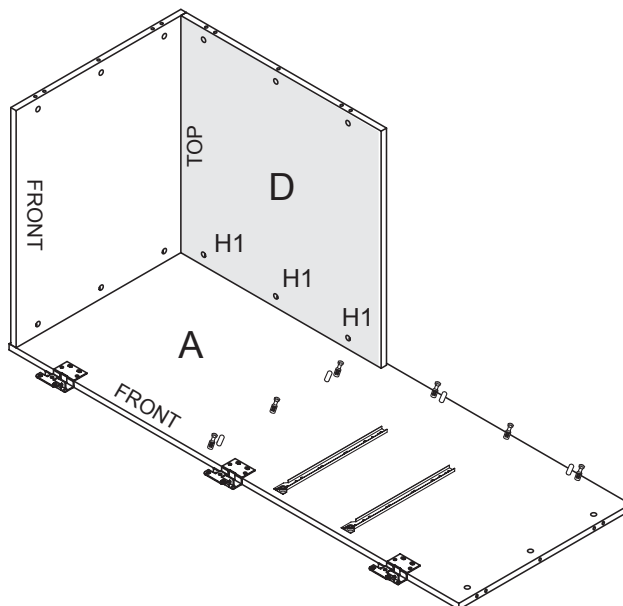

#15

Position the Monitor Shelf (G) with the front edge as shown onto the Left Side (A). Turn the arrows of the cams (H1) clockwise to secure.

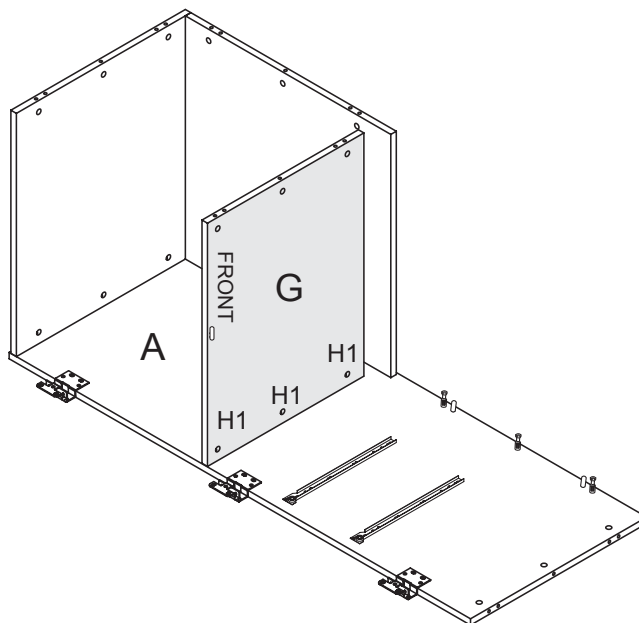

#16

Position the Lower Back (D) with the finished (top) edge as shown onto the Left Side (A). Turn the arrows of the cams (H1) clockwise to secure in place.

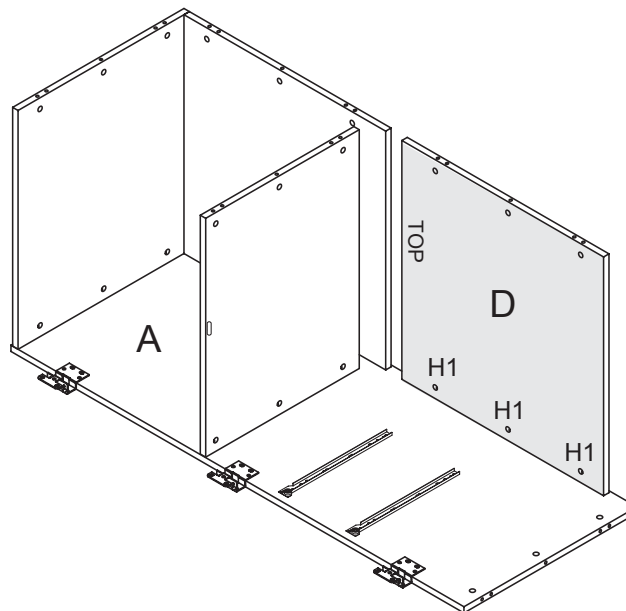

#17

With the help of another person, position the bolts and dowels of the Right Side (B) into the cams of the Top (C), Upper Back (D), Monitor Shelf (G) and Lower Back (D) as shown. Turn the arrows of the cams (H1) clockwise to secure in place.

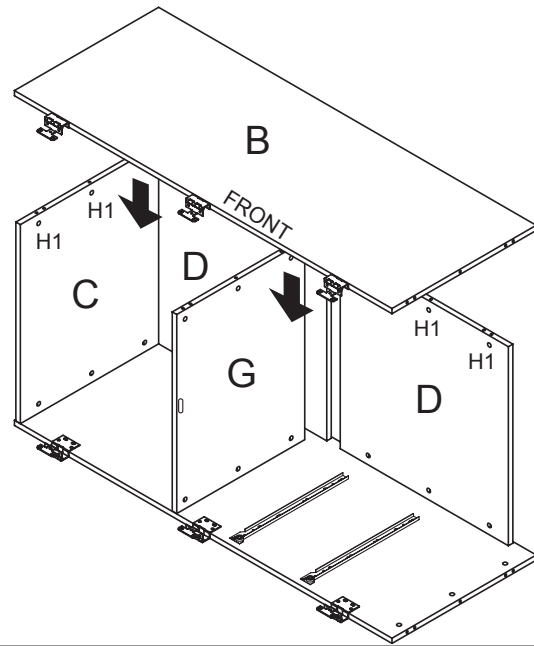

#18

Position the bolts and dowels of the Bottom (E) into the cams of the Sides (A & B) as shown. Turn the arrows of the cams (H1) clockwise to secure in place.

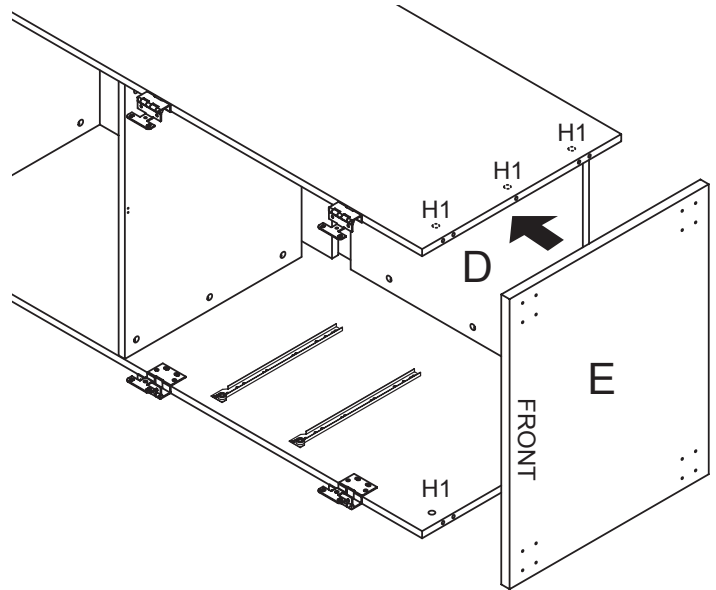

#19

Attach four Plate Casters (H8) to the Bottom (E) using the #14x3/4" Panhead Screws (H9) in the pre-drilled holes as shown.

With the assistance of another person, turn the unit upright.

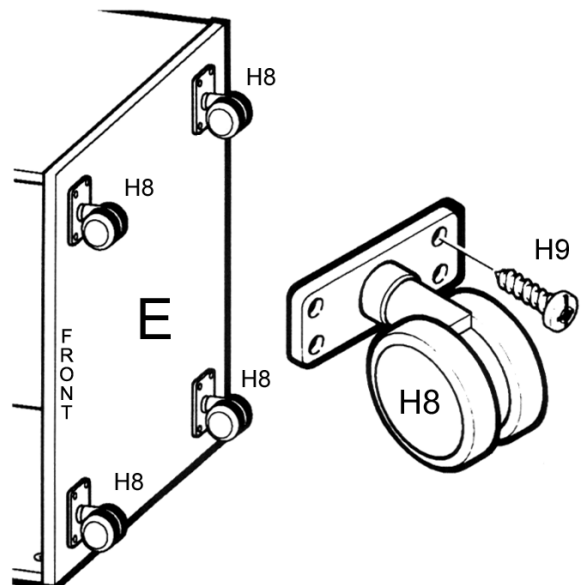

#20

Attach a Stop Plate (H10) to the Left Door (J) using two #8x5/8" Panhead Screws (H7) as shown.

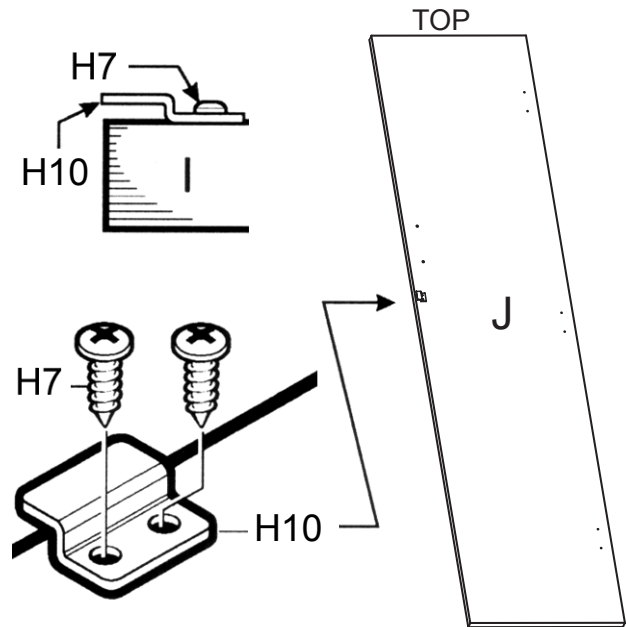

#21

Attach a Door Pull (H12) to the Left Door and Right Door using the 1" Machine Screws (H11).

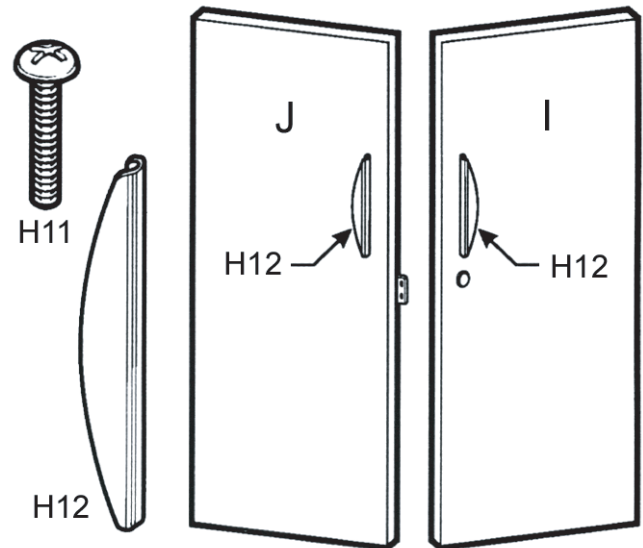

#22

Position the Lock (H13) onto the inner side of the Right Door (J) oriented as shown. Secure the Lock in place using two #6x5/8" Panhead Screws (H14) into the pre-drilled holes of the Right Door. Press the trim ring of the lock over the keyhole portion of the lock on the opposite side of the Right Door as shown.

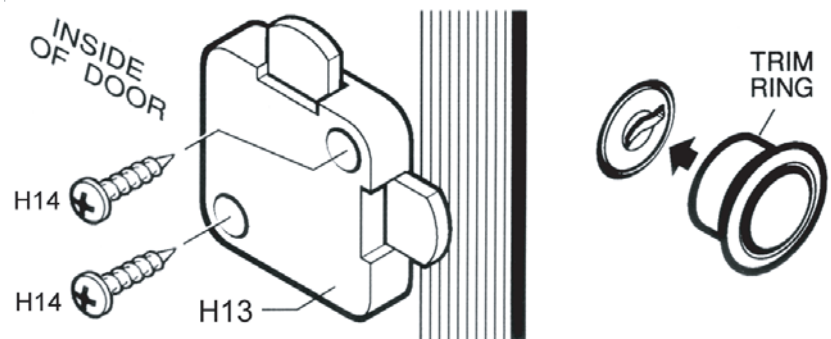

#23

Attach the Left Door (I) using six #8 x 5/8" Flathead Screws (H15) in the pre-drilled holes as shown.

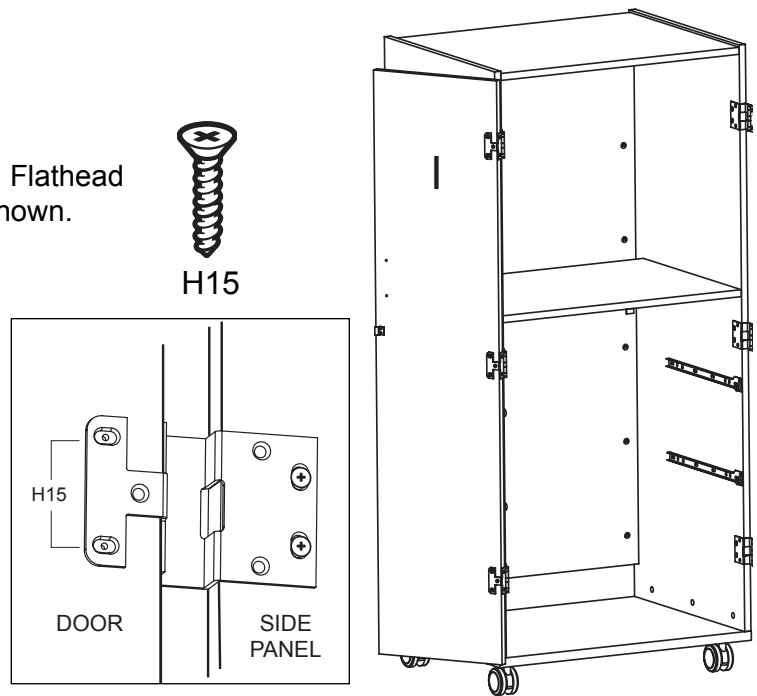

#24

Attach the Right Door (J) using six #8 x 5/8" Flathead Screws (H15) in the pre-drilled holes as shown.

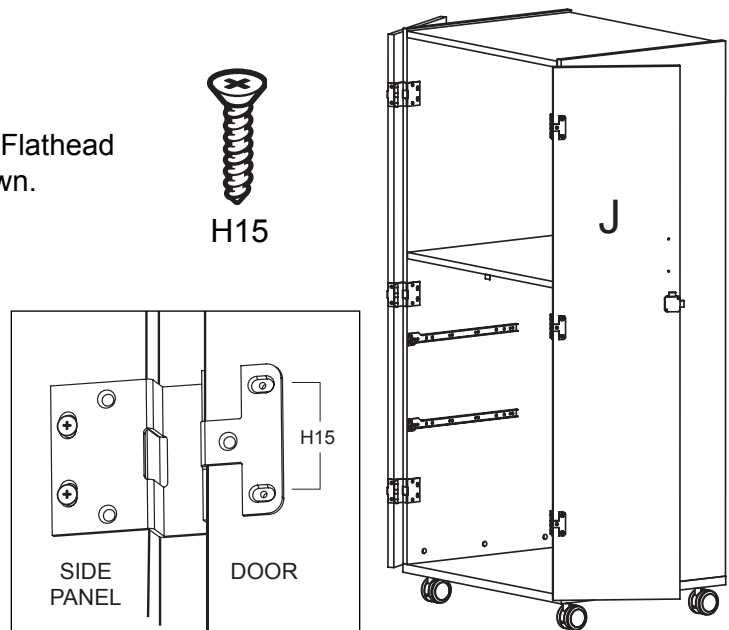

#25

To make adjustments, loosen screws just enough to move horizontally or vertically. Tighten screws when adjustment is appropriate.

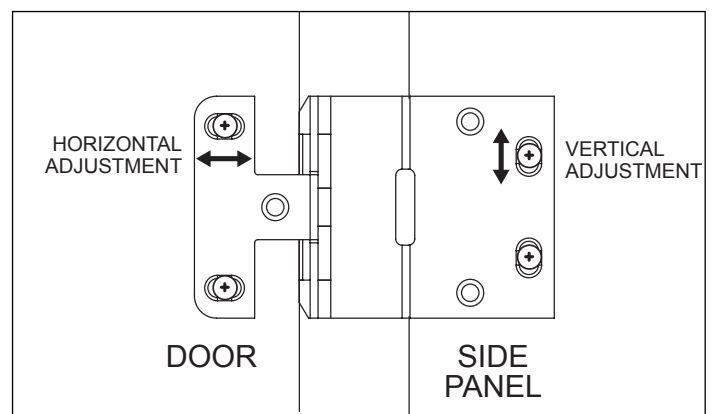

#26

Using a 1/8" diameter Drill Bit, pre-drill a 3/8" deep pilot hole and add remaining screws. There are two places per hinge to add screws to the side panels and three places per hinge to add screws to the doors.

Make adjustments to lock.

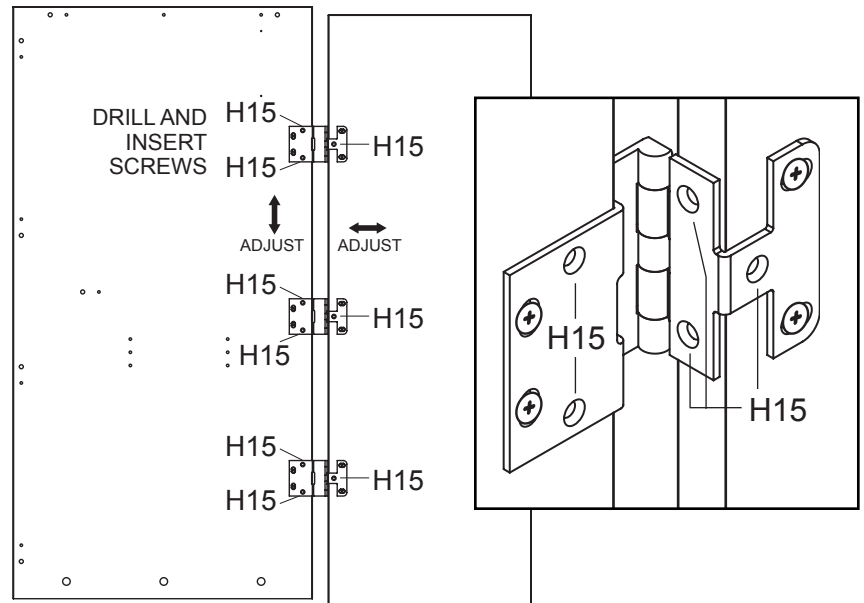

#27

Place the two Adjustable Shelves (K) with pre-drilled holes facing up as shown. Attach left and right Shelf Slides (S3 & S4) using the #6 x 5/8" Panhead Screws (H14) as shown.

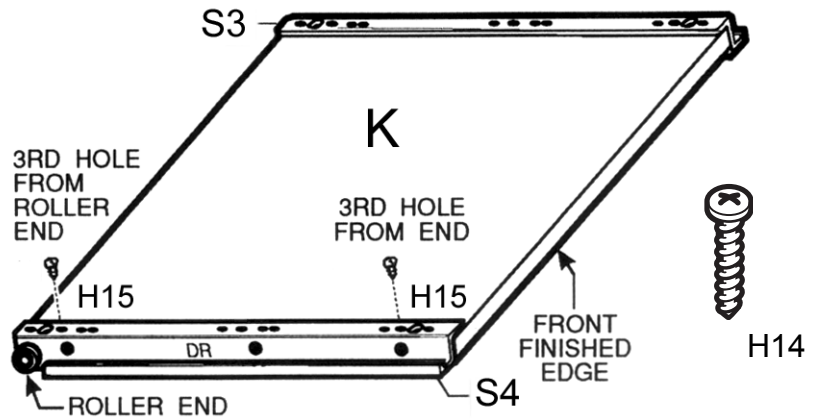

#28

Slide the Adjustable Shelves (K) onto the upper and lower slide channels of the Left Side (A) and the Right Side (B) as shown.

Assembly of the Video Cabinet is now complete.

