

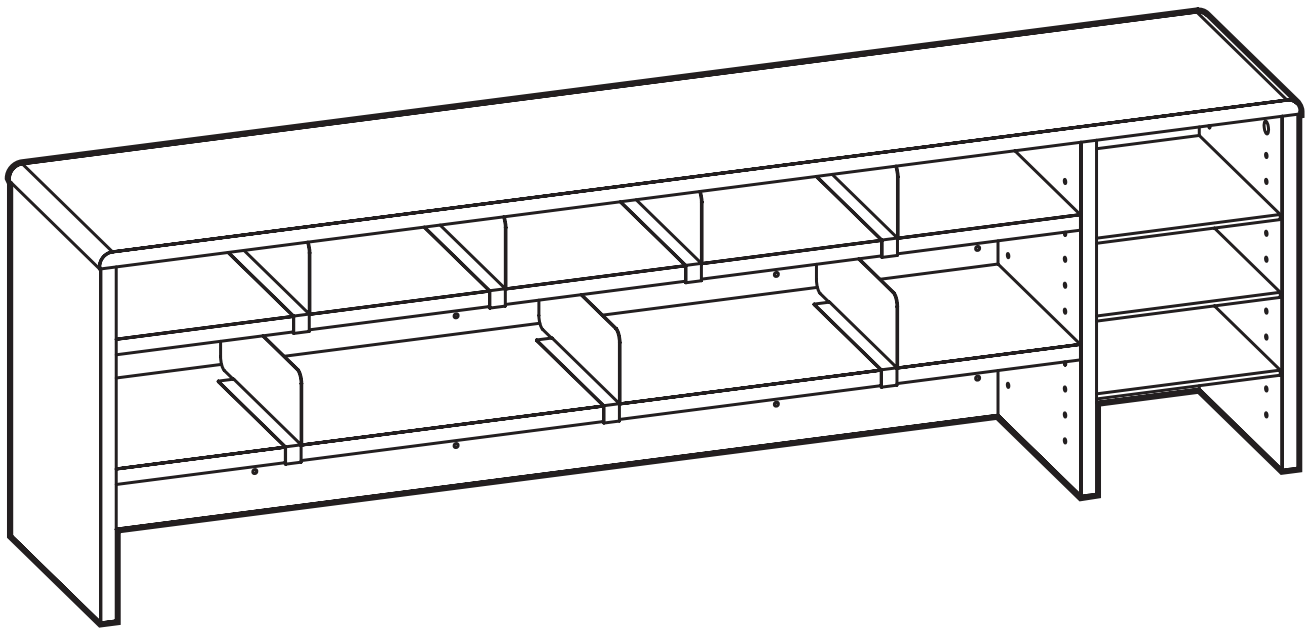

IRONWOOD

DTO-HC

DESKTOP ORGANIZERS



IMPORTANT!

Assembly may require the assistance of another person.

Before you begin assembly:

READ THE DIRECTIONS all the way through one time. This will speed up the process and help you understand the sequence of steps.

COUNT THE PARTS AND HARDWARE before assembly. This ensures you have received all necessary parts before you begin.

TOOLS: You may need a Phillips head screwdriver, a medium slotted screwdriver or a plastic mallet. To protect your new furniture from damage during assembly, it is recommended to work on a carpeted surface.

In the event any parts are missing from this package, send your name, address, telephone number, and a description of the missing part(s) to: **PARTS, Box 1420, Missoula, MT 59806** or call: **1-800-769-5693** or **FAX 1-800-445-5281**.

CAUTION: On assemblies requiring glue, make sure the unit is assembled correctly before gluing. Once this unit is assembled with glue, the manufacturer will not be responsible for damaged parts. Keep a damp cloth or sponge handy to wipe off excess glue.

To care for this furniture, simply wipe with a cloth dampened with glass cleaner containing ammonia-D.

PARTS DIAGRAM

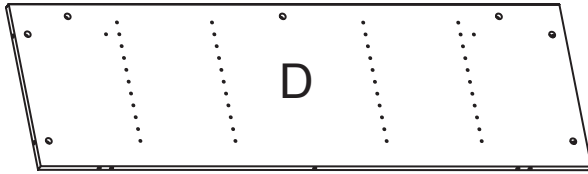

Back	05761552	1 ea.
------	----------	-------

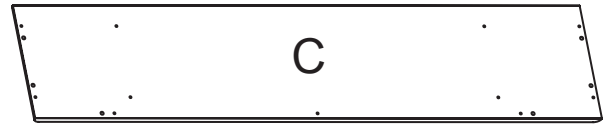

Top	05761501	1 ea.
-----	----------	-------



Shelf	05761521	2 ea.
-------	----------	-------



Adjustable Shelf	00000000	3 ea.
------------------	----------	-------

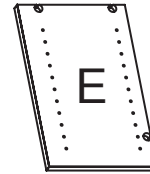

Divider Panel	05761544	1 ea.
---------------	----------	-------

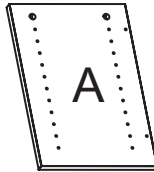

Right Side	05761542	1 ea.
------------	----------	-------

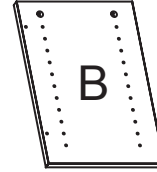

Left Side	05761542	1 ea.
-----------	----------	-------

HARDWARE



H1	Minifix Cam	909810	11 ea.
----	-------------	--------	--------



H2	Minifix Bolt	909834	11 ea.
----	--------------	--------	--------



H3	Dowel	195000	6 ea.
----	-------	--------	-------



H4	Rafix Cam	909910	15 ea.
----	-----------	--------	--------



H5	Rafix Bolt	909923	15 ea.
----	------------	--------	--------



H6	Shelf Support Pin	297210	12 ea.
----	-------------------	--------	--------



H7	Plastic Label Holders	H3404	3 ea.
----	-----------------------	-------	-------

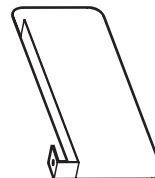

H8	Metal Shelf Dividers	H10100	7 ea.
----	----------------------	--------	-------

Using the Rafix System:

Insert the Rafix Cams into the appropriate holes. The flat edge of the cam should be facing the edge of the panel.

Slide Rafix Cams of the panel to be attached onto the corresponding posts.

When screwing post into hole, **Do Not** over tighten. Screw post down until bottom face of post flange just touches board surface.

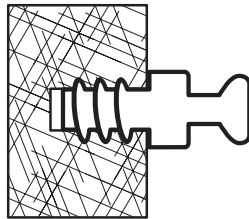

Using a #3 Phillips screwdriver, turn the rotating portion of the Rafix Cam a 1/2 turn clockwise to secure. **IMPORTANT!** Do not exceed 1/2 turn when tightening cams. Turn 1/2 turn counterclockwise to disassemble and remove panel.

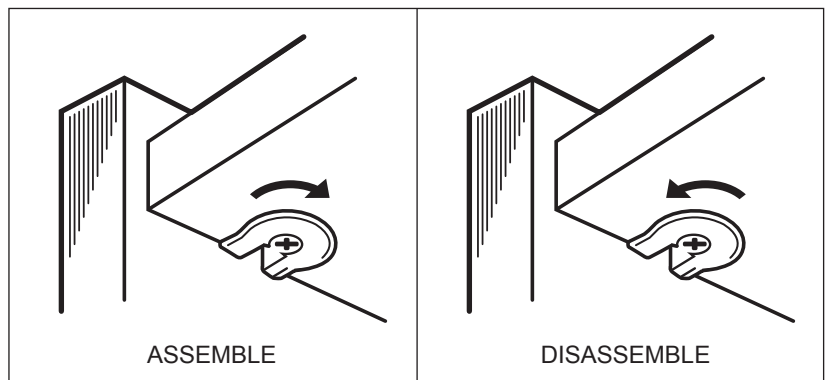
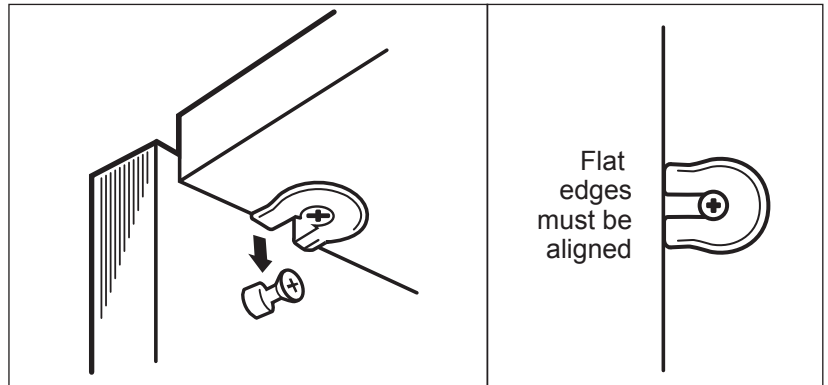

Using the Minifix System:

Insert the Minifix Cams into the appropriate holes with the arrow facing outwards as shown.

When screwing post into hole, **Do Not** over tighten. Screw post down until bottom face of post flange just touches board surface.

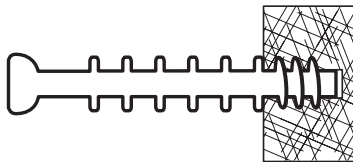

Using the #2 Phillips screwdriver, rotate the Cam Devices a half turn clockwise until snug.

To disassemble, turn the Cam Devices counter-clockwise and remove panels.

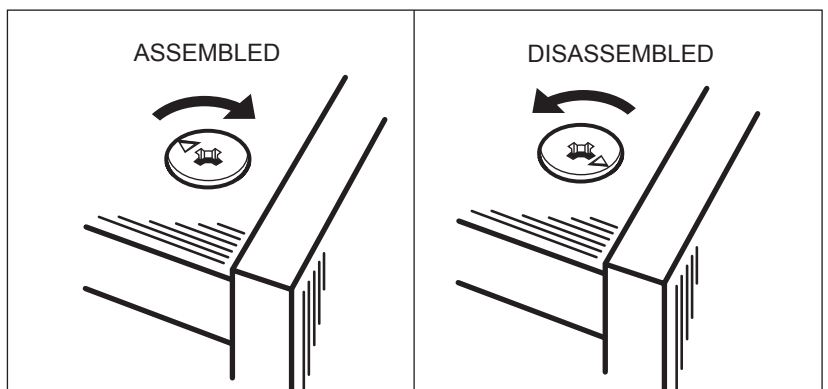
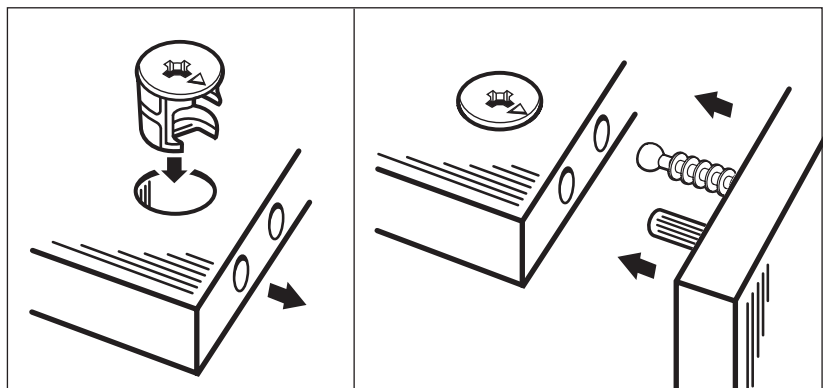

#1

Insert 7 Minifix Cams (H1) into cam holes in Back (D) so that the arrow is facing out.

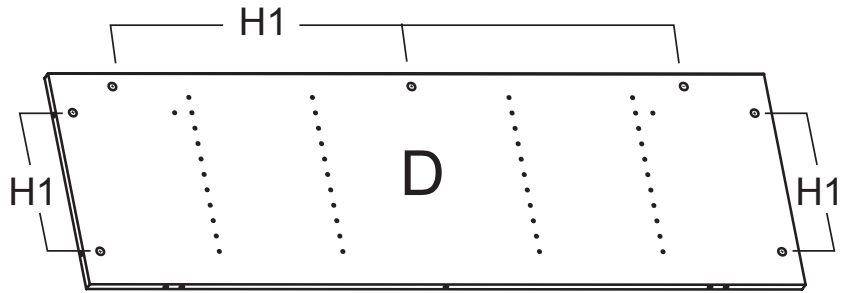

#2

Insert 2 Minifix Cams (H1) into each side (A & B).
Screw in 2 Minifix Bolts (H2) in each of the sides as shown.

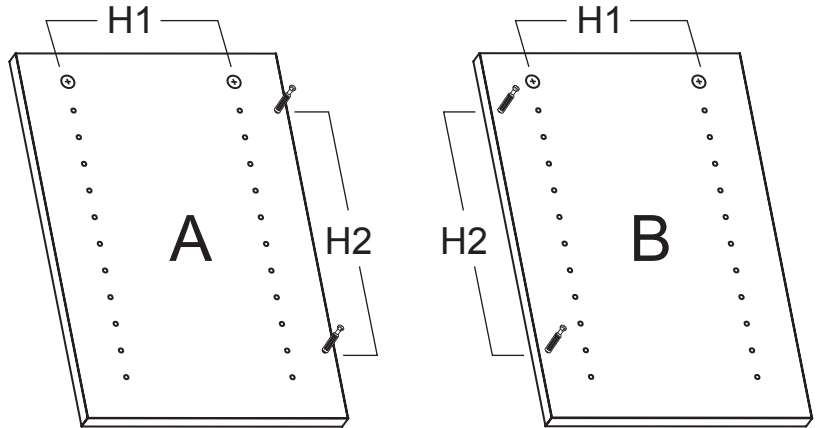
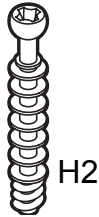

#3

Position Right Side (B) onto back (D) as shown.
Turn Minifix Cams (H1) clockwise to secure.

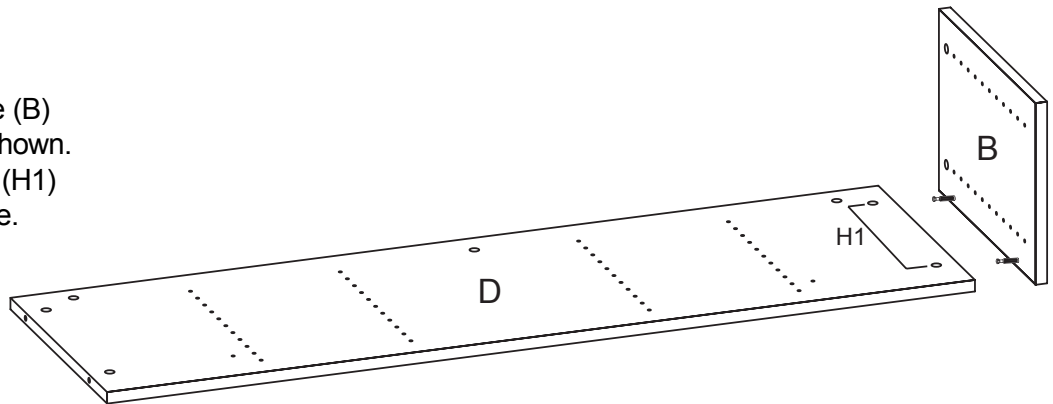

#4

Position Left Side (A) onto back as shown. Turn Minifix Cams (H1) clockwise to secure.

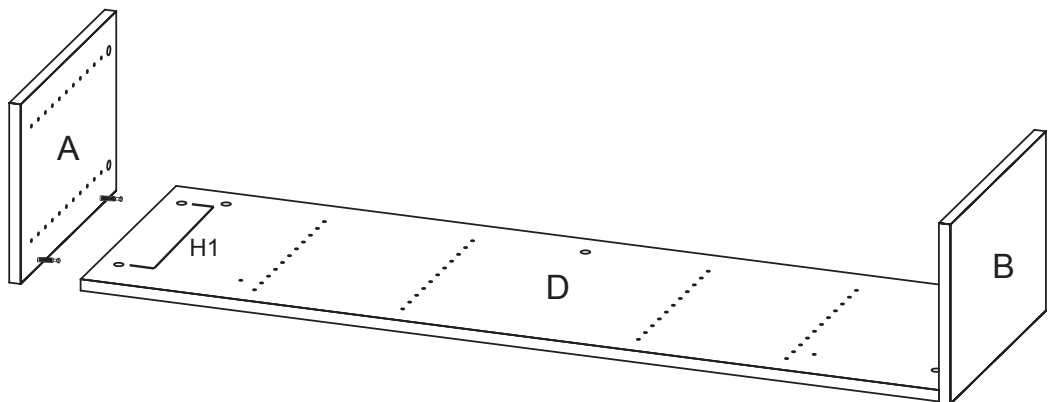

#5

Place Top (C) with drilled holes facing up. Screw in 7 Minifix Bolts (H2) and 6 Wood Dowels (H3) as shown.

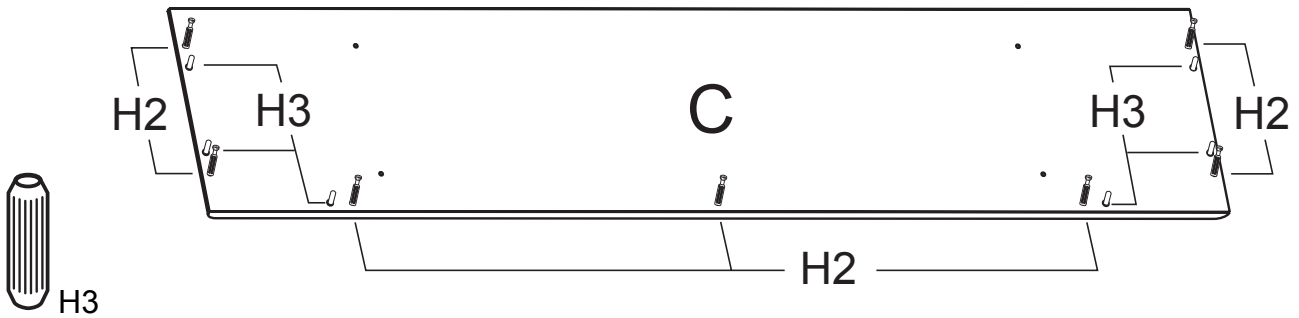

#6

Position Top (C) onto Back (D) and Sides (A & B). Turn Minifix Cams (H1) clockwise to secure.

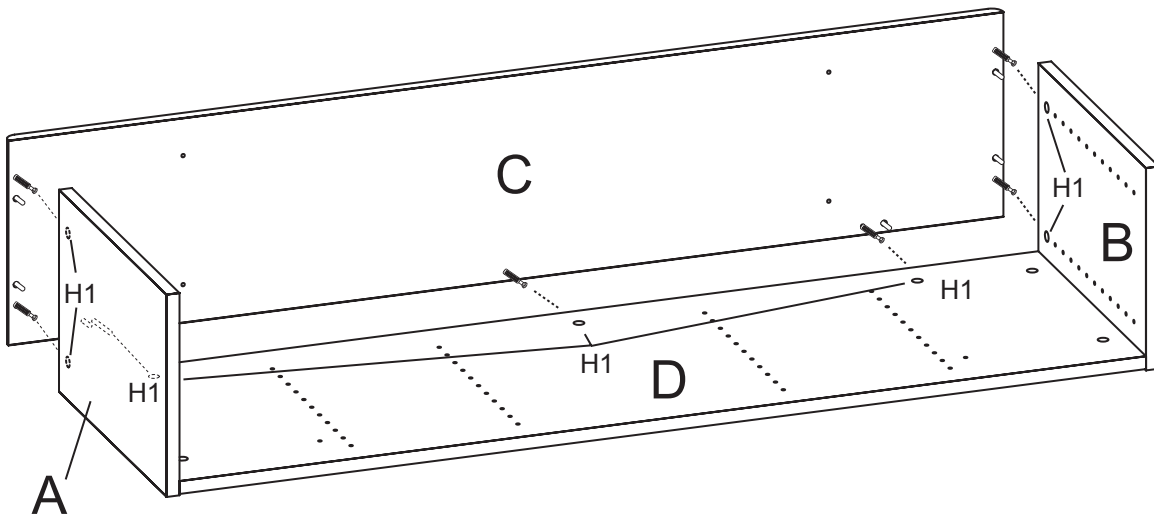

#7

Carefully position and insert 3 Rafix Cams (H4) into Divider Panel (E). Tap Rafix Cams until fully seated.

NOTE: Position as shown, Rafix Cams cannot be repositioned if installed incorrectly.

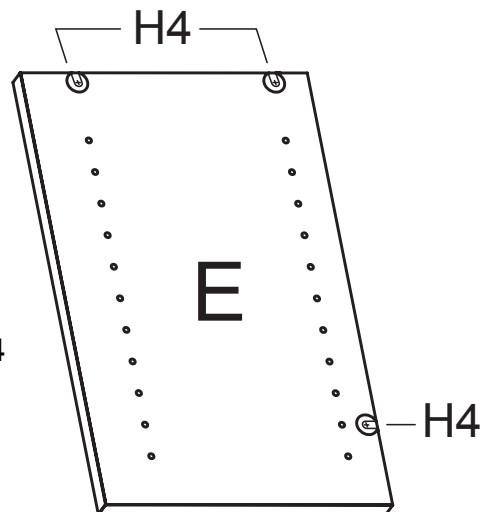

#8

Select side (right or left) for the 3 short shelves you will install later. Screw in 3 Rafix Bolts (H5) as shown. Slide Divider Panel (E) into Rafix Bolts and turn Rafix Cams (H4) clockwise to secure.

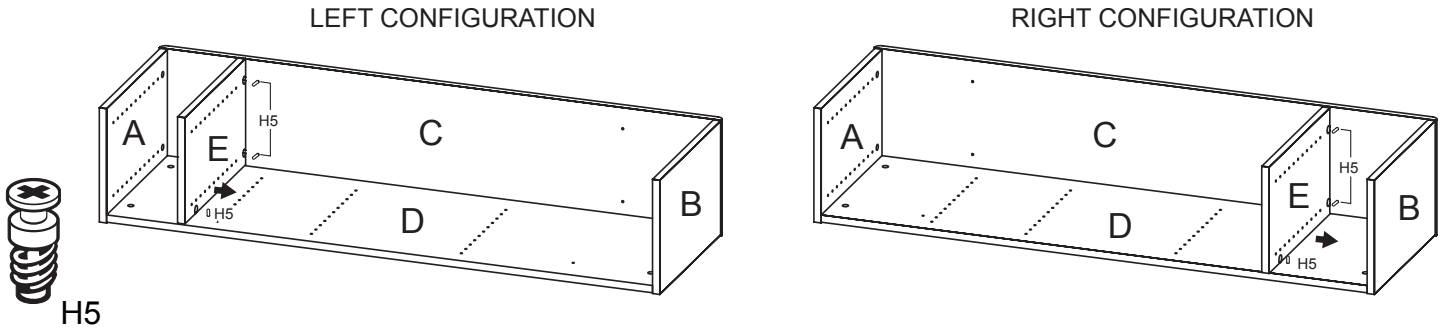

#9

Position Rafix Cams (H5) carefully into the holes on each Shelf (G) as shown. Tap until fully seated.

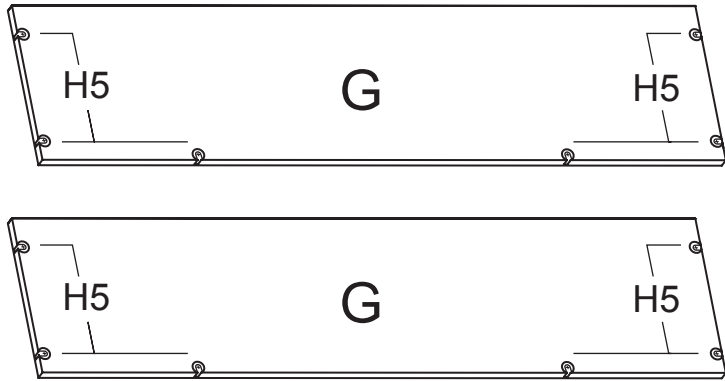

#10

Set unit upright. Select positions for the 2 Shelves (G) in the unit. Screw in 4 Rafix Bolts into the Divider Panel (E) and 4 into Side Panel (A or B) in the selected positions. Screw 4 Rafix Bolts into the Back (D) in matching positions to Divider Panel and Side Panel.

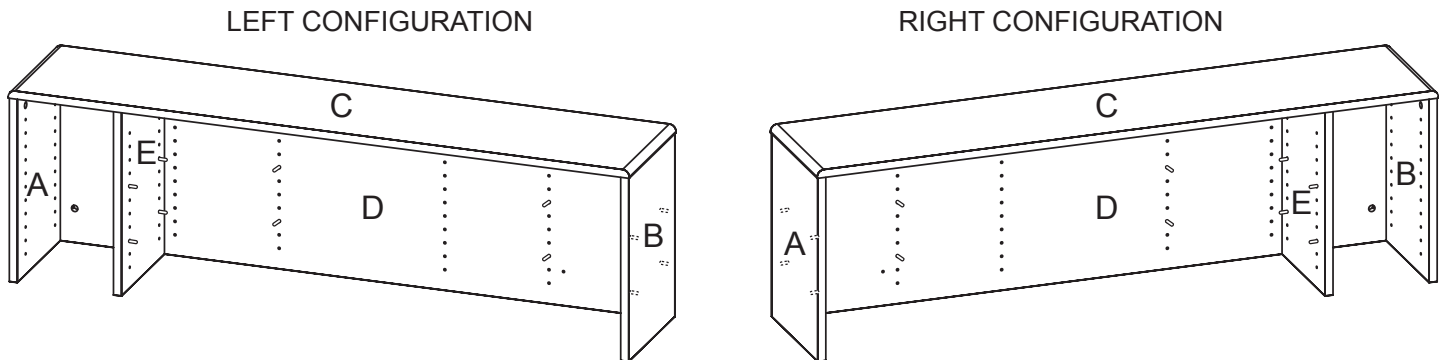

#11

Position Shelf (G) onto upper Rafix Bolts (H5) and secure by turning Rafix Cams 1/2 turn.

LEFT CONFIGURATION

RIGHT CONFIGURATION

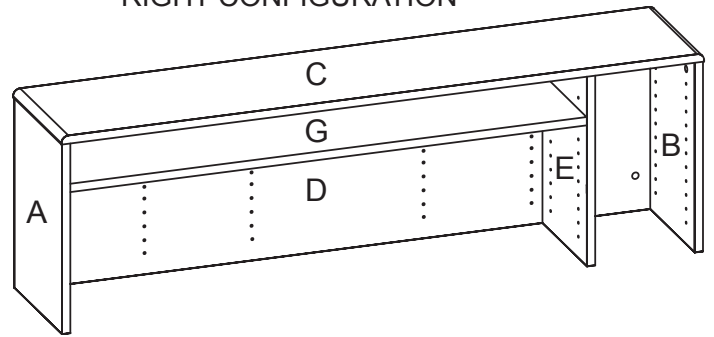
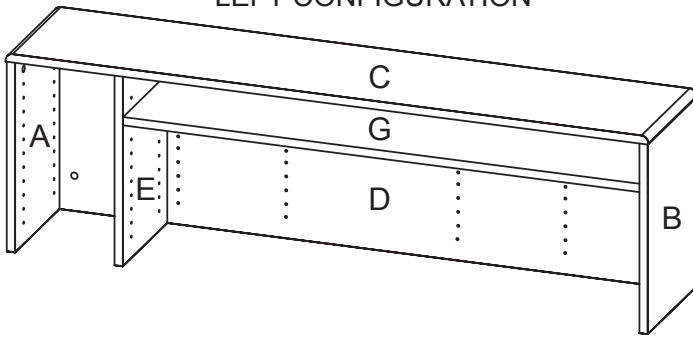

#12

Position bottom Shelf (G) and secure Rafix Cams.

LEFT CONFIGURATION

RIGHT CONFIGURATION

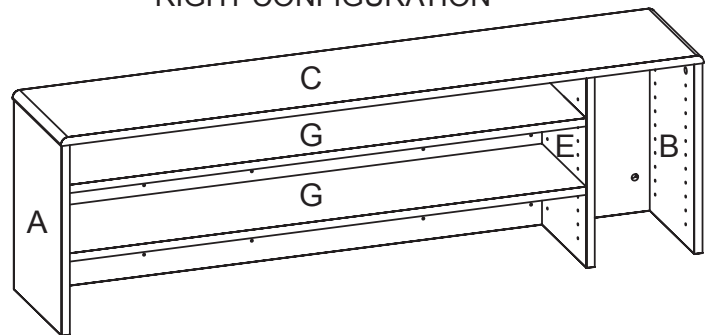
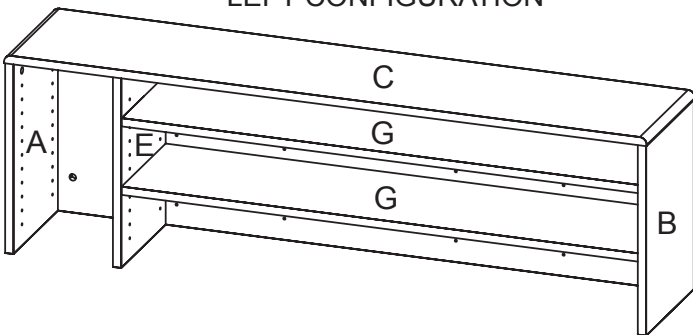

#13

Select location and insert 12 Shelf Support Pins (H6) into side (A or B) and in matching holes on Divider Panel (E).

LEFT CONFIGURATION

RIGHT CONFIGURATION

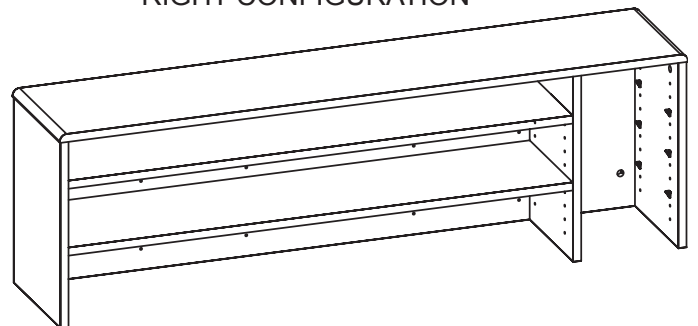
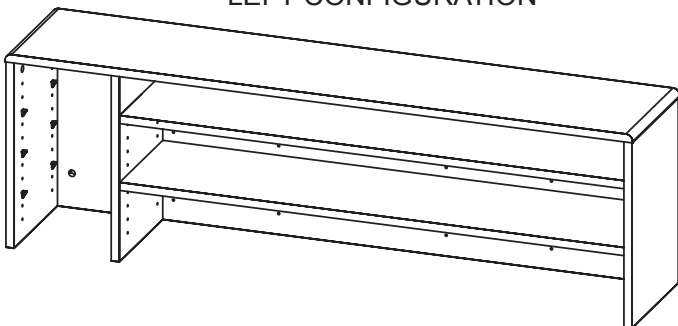

#14

Set the 3 Adjustable Shelves (J) onto the Shelf Support Pins (H6). Press the 3 plastic Label Holder Moldings (H7) onto each of the Adjustable Shelves.

LEFT CONFIGURATION

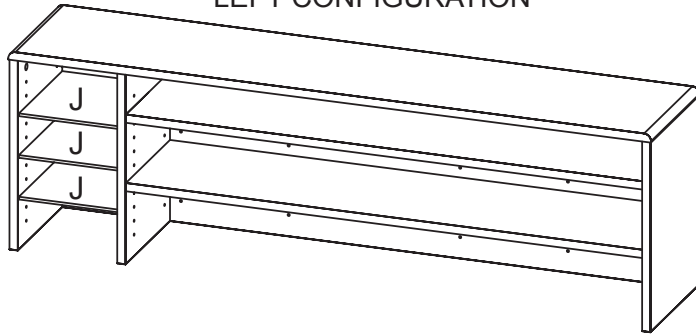

RIGHT CONFIGURATION

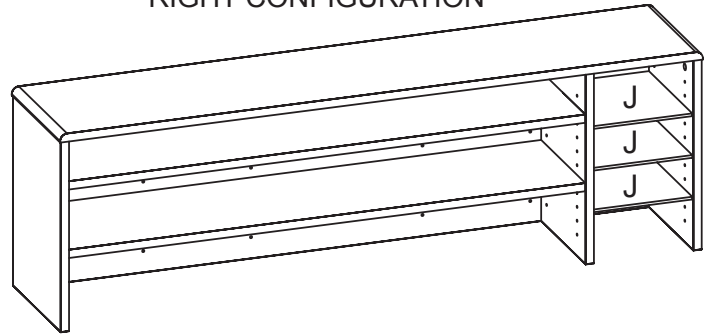

#15

Slide the 7 Metal Shelf Dividers (H8) onto the 2 long Shelves (G) in the positions you choose.

LEFT CONFIGURATION

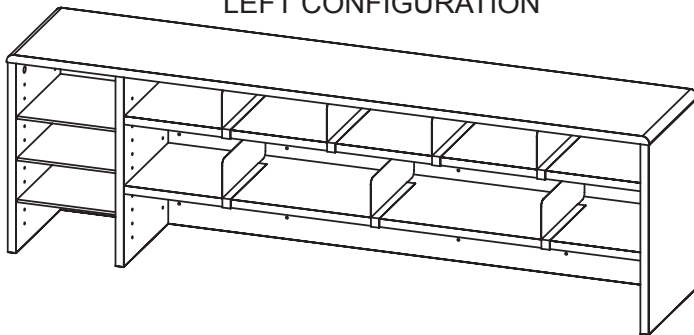

RIGHT CONFIGURATION

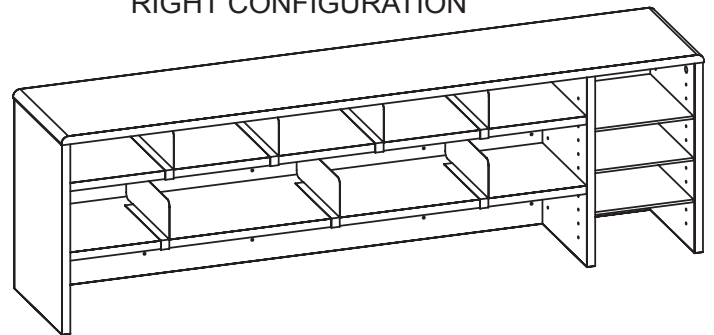

Your High Capacity Desktop Organizer is now assembled and ready to use.