

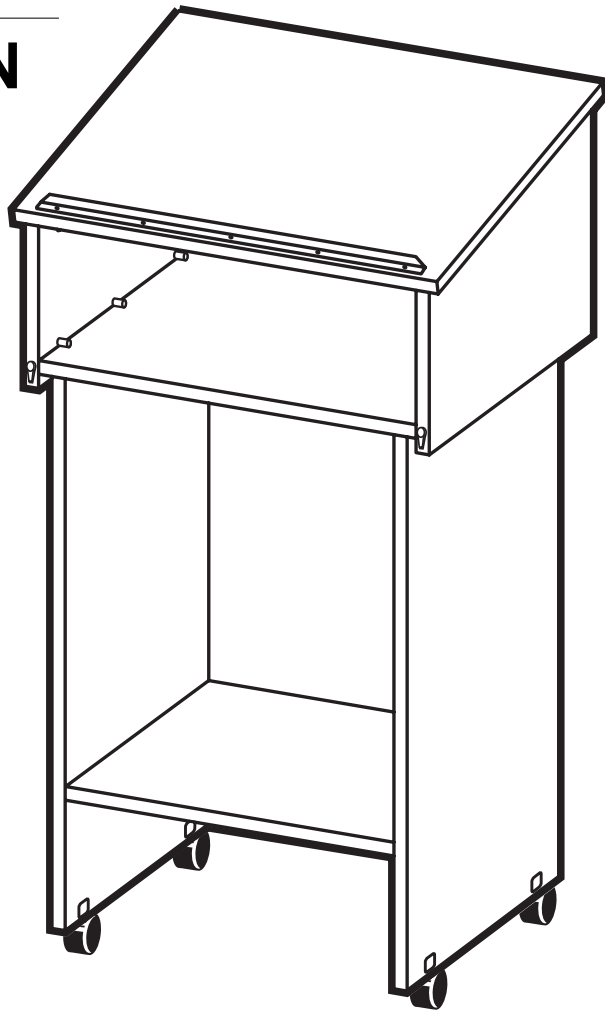

TSL

TWO SECTION LECTERN



IMPORTANT!

Assembly may require the assistance of another person.

Before you begin assembly:

READ THE DIRECTIONS all the way through one time. This will speed up the process and help you understand the sequence of steps.

COUNT THE PARTS AND HARDWARE before assembly. This ensures you have received all necessary parts before you begin.

TOOLS: You may need a Phillips head screwdriver, a medium slotted screwdriver or a plastic mallet. To protect your new furniture from damage during assembly, it is recommended to work on a carpeted surface.

In the event any parts are missing from this package, send your name, address, telephone number, and a description of the missing part(s) to: PARTS, Box 1420, Missoula, MT 59806 or call: 1-800-769-5693 or FAX 1-800-445-5281.

CAUTION: On assemblies requiring glue, make sure the unit is assembled correctly before gluing. Once this unit is assembled with glue, the manufacturer will not be responsible for damaged parts. Keep a damp cloth or sponge handy to wipe off excess glue.

To care for this furniture, simply wipe with a cloth dampened with glass cleaner containing ammonia-D.

PARTS DIAGRAM

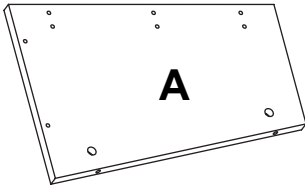

Left Side	05870141	1 ea.
-----------	----------	-------

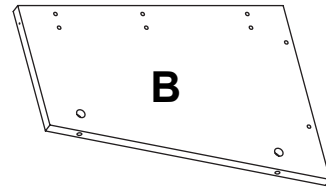

Right Side	05870141	1 ea.
------------	----------	-------

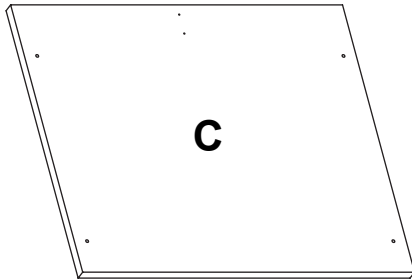

Lectern Top	05870101	1 ea.
-------------	----------	-------

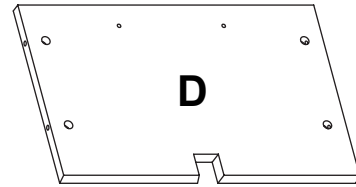

LECTERN Back	05870157	1 ea.
--------------	----------	-------

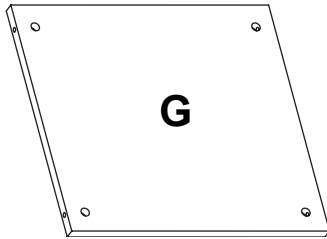

Stand Shelf	05870127	1 ea.
-------------	----------	-------

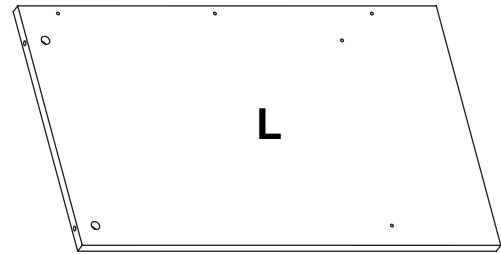

Stand Left Side	05870104	1 ea.
-----------------	----------	-------

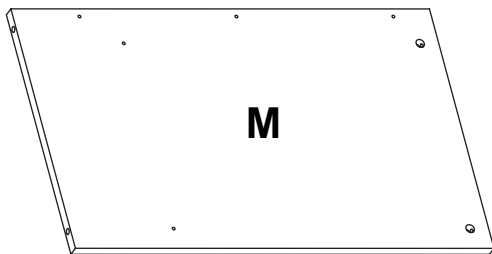

Stand Right Side	05870104	1 ea.
------------------	----------	-------

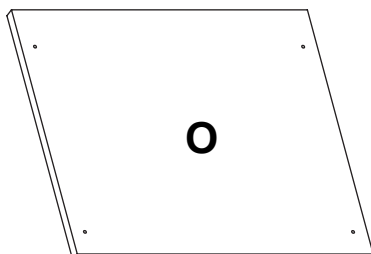

Stand Top	05870105	1 ea.
-----------	----------	-------

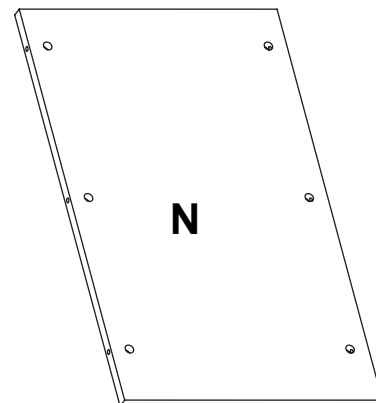

Stand Back	05870160	1 ea.
------------	----------	-------

HARDWARE



H1	Stud	470100	12 ea.
----	------	--------	--------



H2	Minifix Bolt	909834	22 ea.
----	--------------	--------	--------



H3	Minifixs Cam	909810	22 ea.
----	--------------	--------	--------

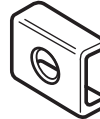

H4	Caster Bracket	402303	4 ea.
----	----------------	--------	-------



H5	Caster Socket	402301	4 ea.
----	---------------	--------	-------

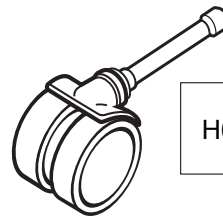

H6	Casters-Locking	402290	4 ea.
----	-----------------	--------	-------

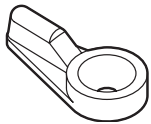

H7	Retaining Buttons	297020	2 ea.
----	-------------------	--------	-------



H8	Phillips Flathead Screw	901118	2 ea.
----	-------------------------	--------	-------

Using the Minifix System:

Insert the Minifix Cams into the appropriate holes with the arrow facing outwards as shown.

When screwing post into hole, **Do Not** over tighten. Screw post down until bottom face of post flange just touches board surface.

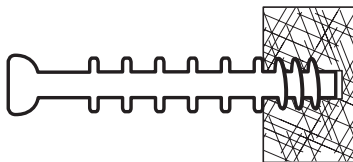

Using the #2 Phillips screwdriver, rotate the Cam Devices a half turn clockwise until snug.

To disassemble, turn the Cam Devices counter-clockwise and remove panels.

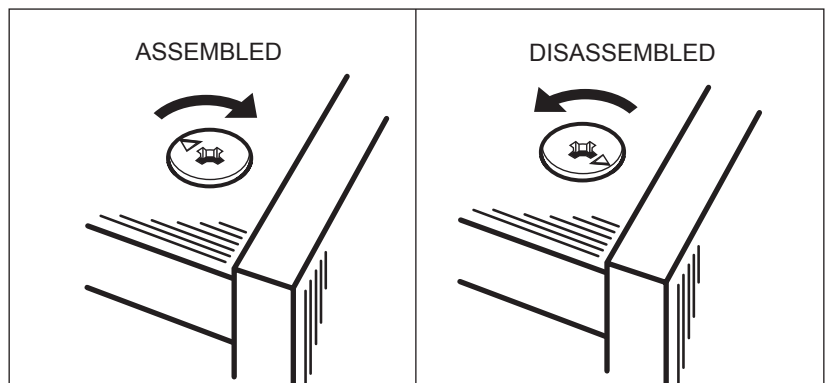
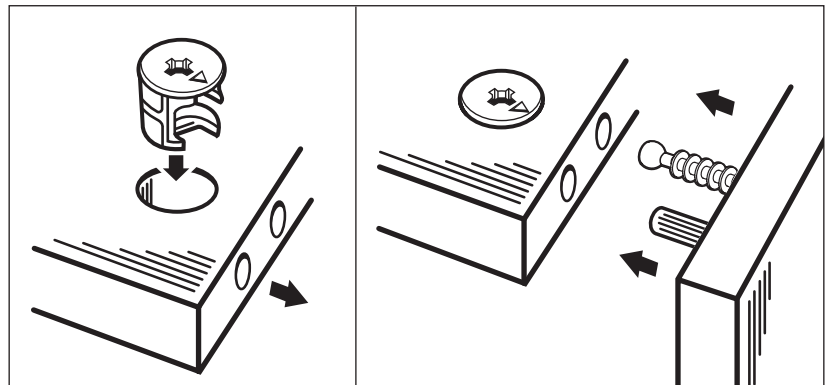

#1

Insert Stud (H1) into the pre-drilled holes of the Lectern Side (A & B) and Lectern Back (D) as indicated and tap into place.

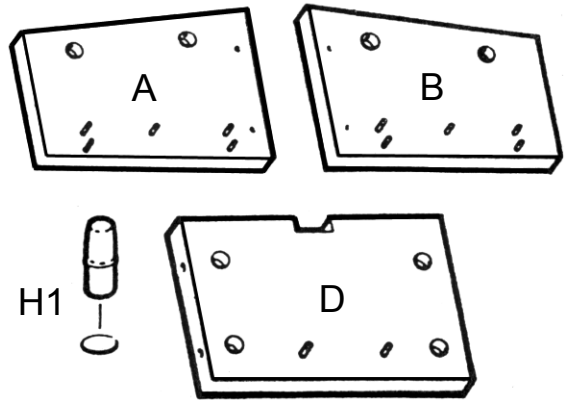

#2

Screw two Minifix Bolts (H2) into each of the Lectern Sides (A & B) as shown and tighten.

Screw four Minifix Bolts into the Lectern Top (C) as shown and tighten.

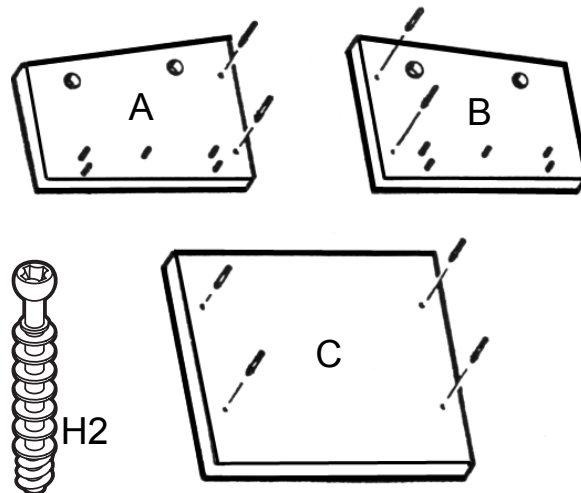

#3

Insert four Minifix Cams (H3) into Back (D).

Position the Lectern Back (D) over the Steel Posts (H2) of Right Lectern Side (B) and rotate Cam Devices (H3) clockwise until secure.

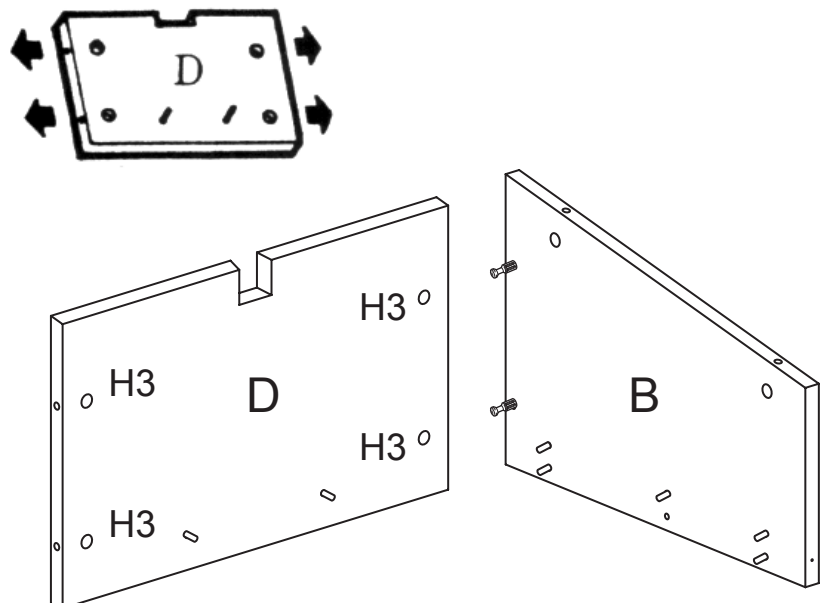

#4

Position the Left Lectern Side (A) posts into the Cam Devices of the Lectern Back (D) and rotate Cam Devices until secure.

Insert two Minifix Cams (H3) into each side of Lectern (A & B) with arrows facing upward.

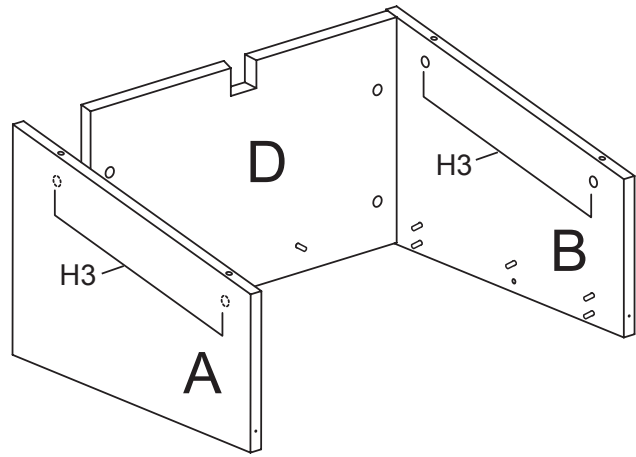

#5

Position Lectern Top (C) over partially assembled unit with Minifix Bolts inserted into corresponding Minifix Cam. Rotate Cam Devices clockwise until secure.

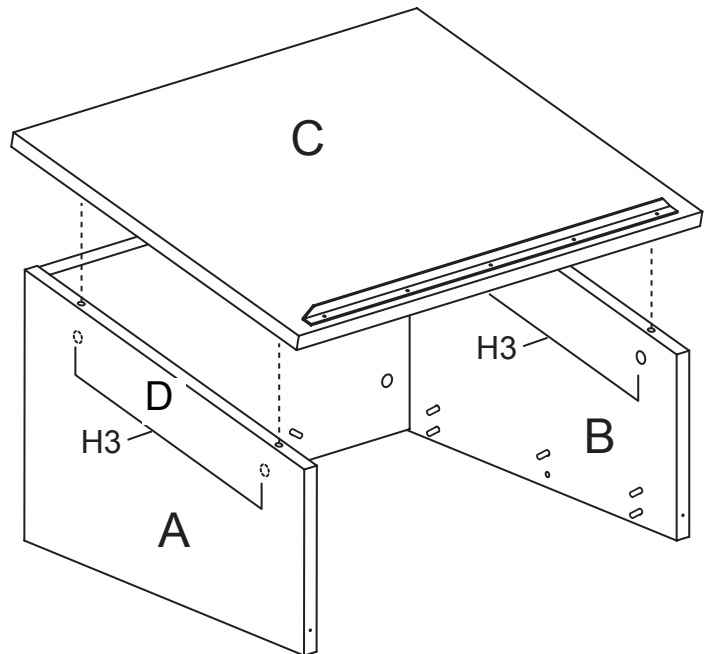

#6

Attach Retainer Buttons (H7) to each of the Lectern Sides (A & B) using Flathead Screws (H8) in pre-drilled holes as shown.

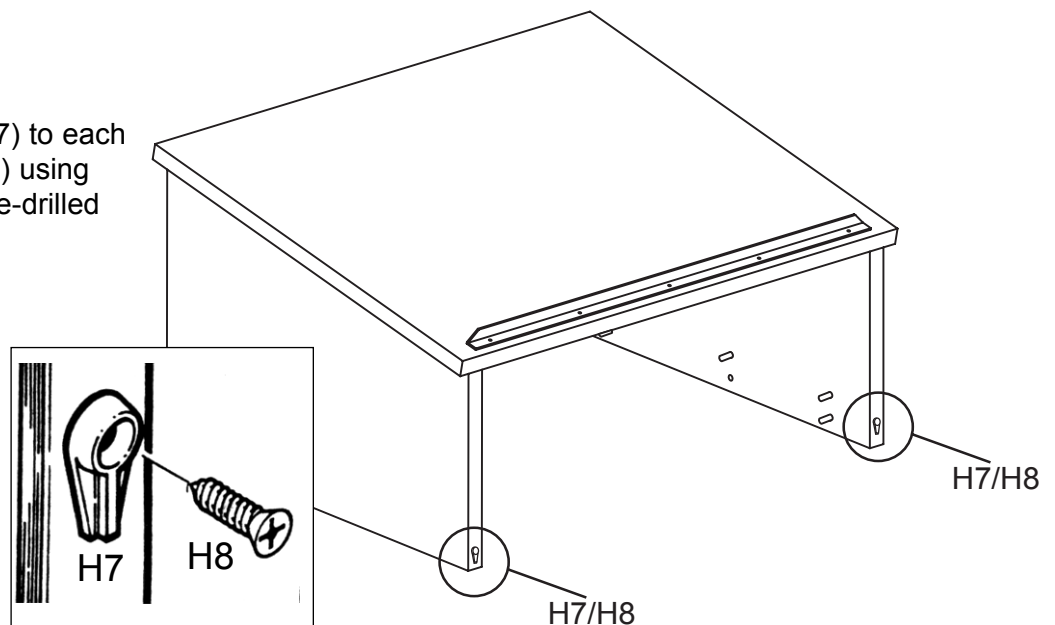

ASSEMBLY OF STAND

#7

Screw Minifix Bolts (H2) into Stand Top (O) and Sides (L & M) as indicated and tighten.

Insert two Minifix Cams (H3) into sides L & M.

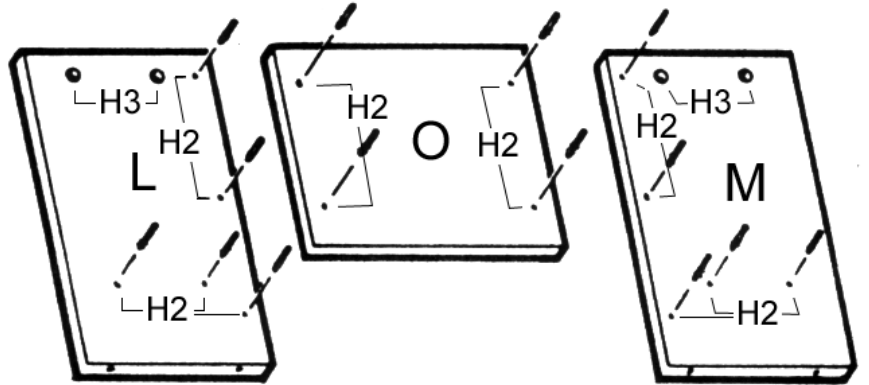

#8

Insert minifix cams (H3) into Back (N).
Position Stand Back onto corresponding posts of Left Side (L)
and rotate Minifix Cams clockwise until secure.

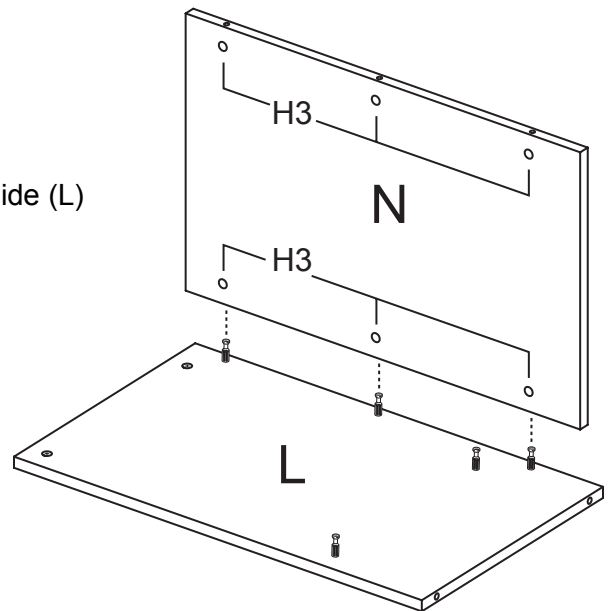

#9

Insert Cam Devices (H3) into Shelf (G). Position Shelf onto
Left Side (L) and rotate Minifix Cams (H3) to secure.

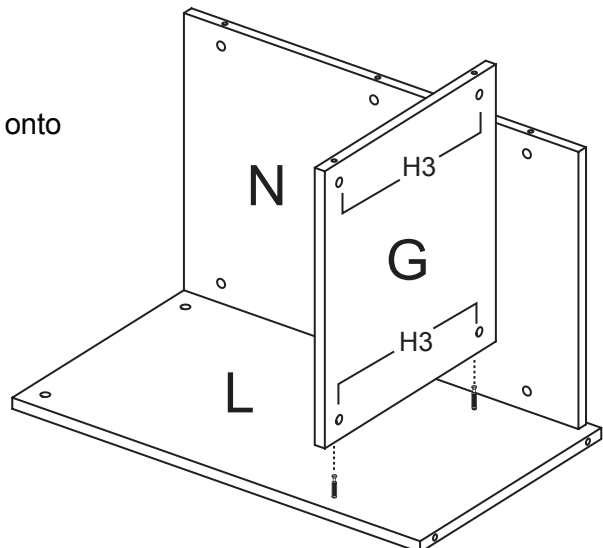

#10

Position Right Side (M) over partially assembled unit with posts inserted into holes and cam devices as shown.

Turn corresponding Minifix Cams to secure.

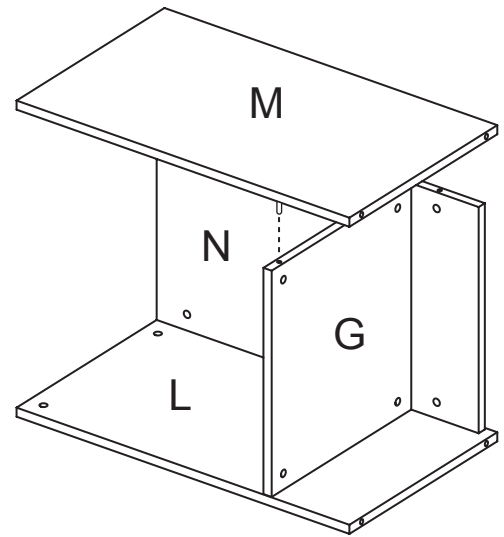

#11

Insert Caster Sockets (H5) through the Caster Brackets (H4) and into corresponding holes in the bottoms of the Sides. Tap into place as shown.

Insert Casters (H6) into Caster Sockets (H5) as shown and tap into place. Note: The Locking Casters should be placed to the rear of the unit.

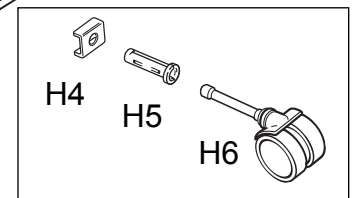
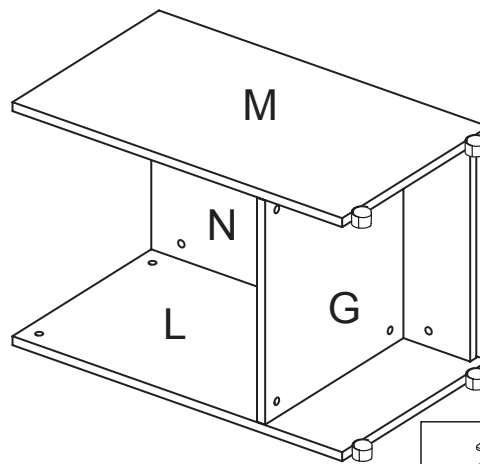

#12

Turn the unit upright.

Position Stand Top (O) posts into corresponding holes and cam Devices of the Sides as shown. Rotate Cam Devices to secure.

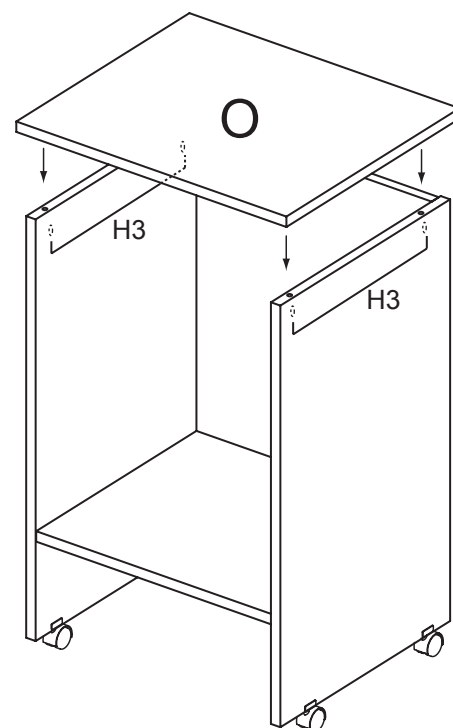

#13

To use as a single unit:

Rotate Retainer Buttons (H7) up as shown. Slide Stand Top edges through Dowels till secure.

Rotate Retainer Buttons to side to lock unit in place.

