

# Combi®

# Coccoro®

## Convertible Car Seat

Compact & Colorful

3 to 40 lbs. (1.4 to 18 kg)

### **⚠️ WARNING**

- **Correct installation and use can be a matter of Life or Death!**
  - **Read and understand these instructions and the labels on the car seat before using this car seat.**
- 
- Certified for use in motor vehicles and aircraft.
  - Meets or exceeds all applicable requirements of Federal Motor Vehicle Safety Standard 213.

Para instrucciones en Español,  
llamar al: 1-800-992-6624  
or log onto [www.CombiUSA.com](http://www.CombiUSA.com).

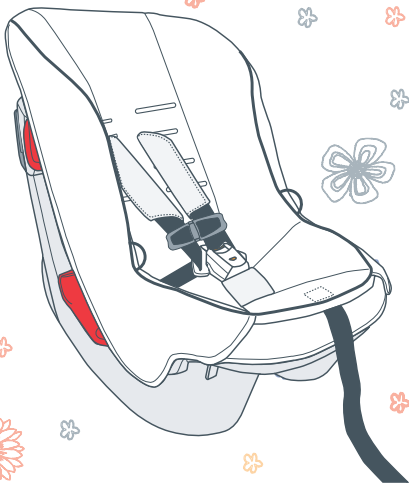

*Coccoro 8220 Series*

# Section 1 - Table of Contents

Section 1.	Table of Contents.....	1
Section 2.	Warnings.....	3
Section 3.	Proper Use Check List.....	5
Section 4.	Assistance.....	6
Section 5.	Car Seat Parts	
	• Child ID Label Location.....	7
Section 6.	Use Recommendations.....	11
Section 7.	Preparing Car Seat For Use	
	• Rear-Facing Use - 33 lbs. (15 kg) or less.....	13
	• Forward-Facing Use - 20 lbs. (9 kg) or more.....	14
Section 8.	Selecting A Vehicle Seating Location.....	15
Section 9.	LATCH System.....	19
Section 10.	Rear-facing Installation	
	10a Rear-facing Installation With LATCH.....	22
	10b Rear-facing Installation With Vehicle Seat Belt.....	28
Section 11.	Forward-facing Installation	
	11a Forward-facing Installation With LATCH.....	34
	11b Forward-facing Installation With Vehicle Seat Belt.....	41
Section 12.	Securing Child In Car Seat.....	46

Section 13. Operation and Adjustments	
13a. Harness Use and Adjustment.....	52
13b. Changing Harness Slot Positions.....	56
13c. Infant Inserts (Use with infants less than 25 lbs. (11.4 kg)).....	61
13d. Rear-facing Tether Attachment Strap Installation.....	62
Section 14. Vehicle Seat Belts.....	64
Rear-facing Belt Lock-off.....	69
Section 15. Additional Information	
• Certification.....	71
• Aircraft Use.....	71
• Warm Weather.....	71
• Vehicle Seat Protection.....	71
• Car Seat Useful Life.....	71
• Instructions Manual Storage.....	71
Section 16. Care And Cleaning.....	72
Section 17. Registration Information.....	73
Section 18. Re-use After A Crash.....	74
Section 19. Limited Warranty.....	75

Keep this instruction manual for future use.  
Store instruction manual in pocket at top of seat back.

## Section 2 - Warnings

### **⚠️ WARNING** - DEATH or SERIOUS INJURY can occur

- Failure to follow these instructions and car seat labels can result in injury or death to a child from striking the vehicle's interior during a sudden stop or crash.
- Use only in a rear-facing position when using this car seat with an infant less than one year old and weighing less than 20 pounds (9 kg).
- Use only with children who weigh between 3 and 40 pounds (1.4 and 18 kg) and whose height is 40 inches (102 cm) or less.
- Discontinue use when child's weight exceeds 40 pounds (18 kg) or shoulders are above the top harness slots.
- Snugly adjust harness provided with the car seat around child.
- For proper harness fit and crash protection:
  - For rear-facing, shoulder harness slots **MUST** be at or below shoulder and harness **MUST** be snugly adjusted. Recheck for small infants.
  - Infant seat insert **MUST** be used for children less than 25 lbs. (11.4 kg).
  - Discontinue use of the infant inserts when shoulders are above the top shoulder strap slots forward-facing or shoulder straps become too short to fit child.

- **Secure this child restraint with the vehicle's LATCH System if available or with a vehicle seat belt as shown in this manual.**
- **LATCH System or vehicle seat belt MUST stay tightly adjusted around car seat at all times.**
- **Secure the top tether strap provided with this child restraint as specified in this instruction manual.**
- **Securely belt this car seat in vehicle, even when not occupied. An unsecured car seat can injure other occupants in a crash.**
- **Never leave child unattended, even when sleeping.**
- **Strangulation Hazard: Child can strangle in loose harness straps. Never leave child in car seat when straps are loose or unbuckled.**
- **DO NOT use accessories or parts other than those provided by Combi USA, Inc. Use of accessories or parts from other manufacturers could alter the performance of the car seat.**
- **DO NOT allow any re-use of this car seat after a crash unless crash and car seat meet ALL conditions in "Re-use After A Crash" section of this manual.**
- **DO NOT use this car seat if it is damaged, missing instructions, or missing parts.**
- **Register your child restraint with the manufacturer.**

## Section 3 - Proper Use Check List

- Proper use is required. Read and understand instructions and car seat labels.

**⚠ WARNING** - DEATH or SERIOUS INJURY can occur

**DO NOT place rear-facing child seat on front seat with air bag. DEATH OR SERIOUS INJURY can occur.**

**The back seat is the safest place for children 12 and under.**



- Owners of vehicles with front passenger side air bags should refer to their vehicle owner's manual for child restraint installation instructions.
- Securely install car seat with LATCH System or vehicle seat belt and top tether strap.
- All infants less than one year old and 20 lbs. (9 kg) must use car seat rear-facing.
- Snugly adjust harness around child.
- Infant insert **MUST** be used for children less than 25 lbs. (11.4 kg).
- Secure children in back seat whenever possible.
- Never leave child unattended.
- Do not allow anyone (babysitter, relatives, etc.) to use car seat without first reading and understanding all instructions and car seat labels.

## Section 4 - Assistance

### NEED HELP?

Contact Combi USA Customer Care at 1-800-992-6624, log onto Combi Customer Care at [www.CombiUSA.com](http://www.CombiUSA.com) or one of the following resources:

- Your vehicle dealer to locate a child safety seat Inspection station in your area.
- Call 1-866-SEAT CHECK (1-866-732-8243).
- Log onto [www.nhtsa.dot.gov](http://www.nhtsa.dot.gov)
  - Click on “Child Safety”.
  - For a car seat inspection station use “Child Safety Seat/Inspection Station Locator”.
- Log onto [www.seatcheck.org](http://www.seatcheck.org).

### *Proper Use Is Required:*

No car seat can guarantee protection from injury in every situation, but proper use helps reduce the risk of serious injury or death.

## Section 5 - Car Seat Parts

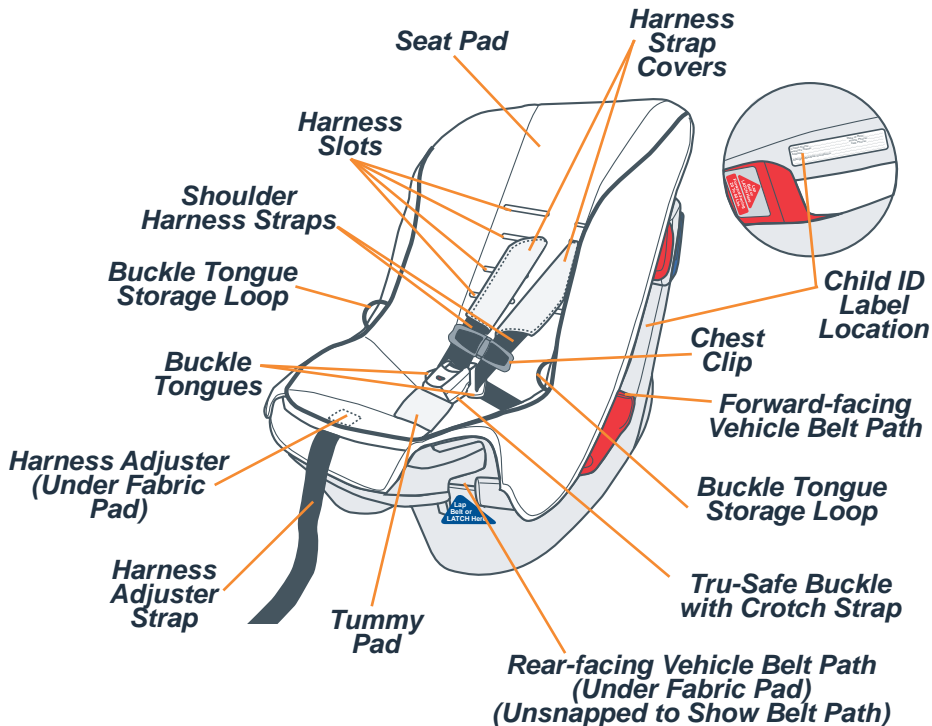



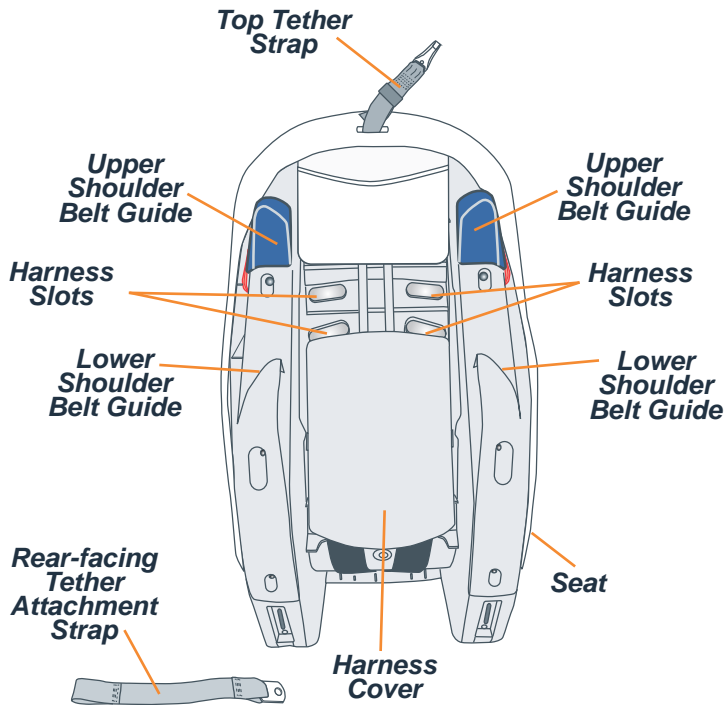

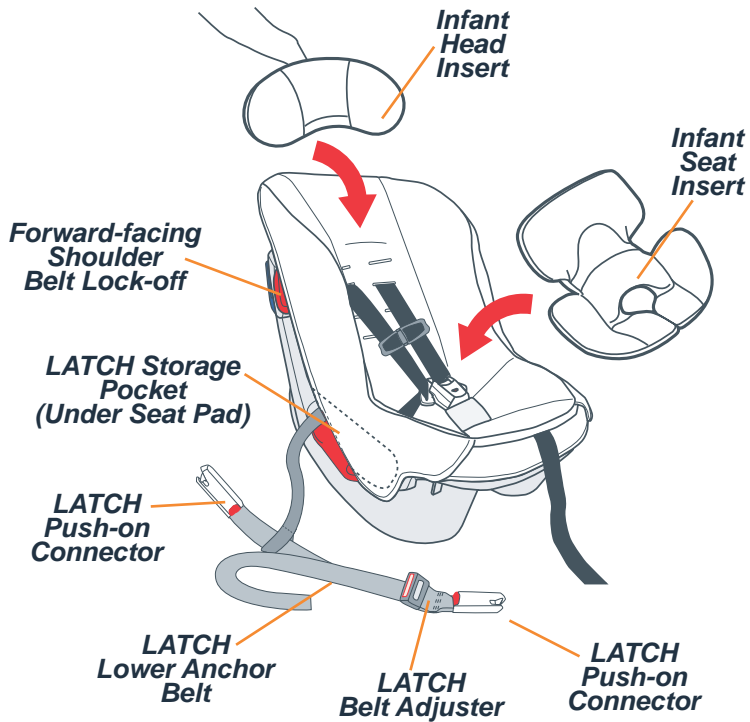

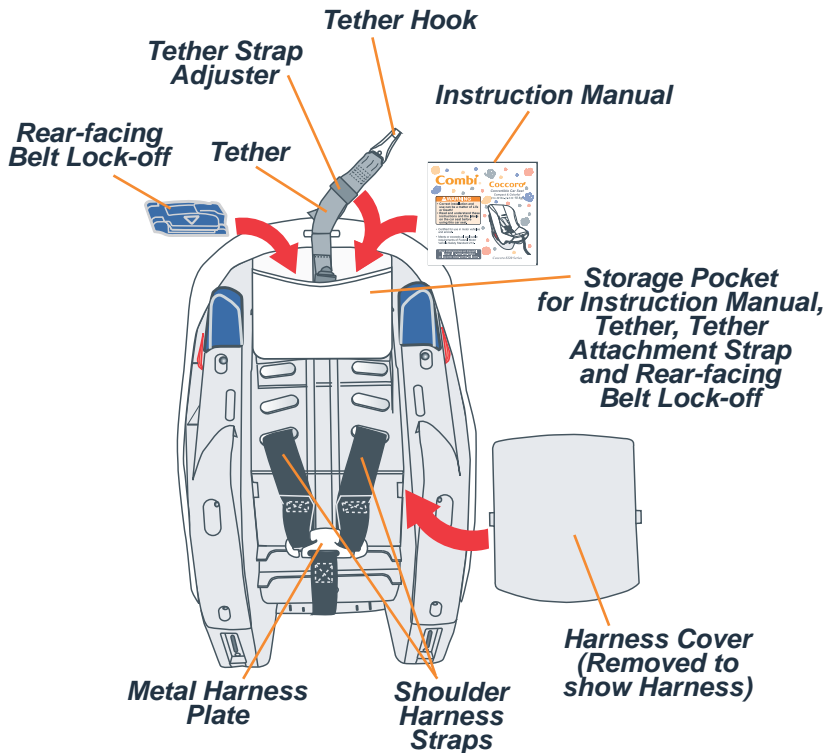

## Section 6 - Use Recommendations

### **WARNING** - DEATH or SERIOUS INJURY can occur

- **Children less than one year old and 20 lbs. (9 kg) must use this car seat rear-facing. Serious crippling injury or death can result if infant faces front of vehicle.**

### Height and Weight Limits:

This child restraint is designed for use only by children whose:

- Weight is between 3 and 40 pounds (1.4 and 18 kg) and,
- Height is between 19 and 40 inches (48 and 102 cm).

### Infants With Special Needs

A preterm infant or low birth weight infant may be at special risk traveling reclined in a vehicle or aircraft. According to the American Academy of Pediatrics, these infants may be at increased risk of suffering breathing or other difficulties if improperly reclined or positioned in a car seat.

Have your physician or hospital staff evaluate your infant in this car seat before you and your infant leave the hospital. If your infant is not able to travel in a reclined position, **DO NOT** use this car seat. Use a car bed for your infant.

### **Rear-facing Use: 3 to 33 lbs. (1.4 to 15 kg)**

- Shoulder harness slots **MUST** be at or below shoulder and harness **MUST** be snugly adjusted. Recheck for small infants.
- All infants less than one year old and 20 lbs. (9 kg) **MUST** be *rear-facing*.
- Infant seat insert **MUST** be used for children less than 25 lbs. (11.4 kg).
- Children 20 to 33 lbs. (9 to 15 kg) and up to 36 inches (91 cm) tall can use car seat *rear-facing*.



### **Forward-facing Use: 20 to 40 lbs. (9 to 18 kg)**

- Toddlers 20 to 33 lbs. (9 to 15 kg), over one year of age, and who are capable of sitting upright unassisted may be forward-facing. If unable to sit unassisted, use rear-facing.

The American Academy of Pediatrics recommends keeping children over 1 year of age rear-facing as long as possible.

- Infant seat insert **MUST** be used for children less than 25 lbs. (11.4 kg).
- Toddlers 33 to 40 lbs. (15 to 18 kg) and up to 40 inches (102 cm) tall **MUST** be forward-facing.



## **⚠️ WARNING - DEATH or SERIOUS INJURY can occur**

- Children **MUST** be over one year of age to use car seat forward-facing.
- To avoid injuries from whiplash, top of child's ears must be below top edge of car seat.
- Child's shoulders **MUST** not be above top harness slots.

## Section 7 - Preparing Car Seat For Use

The Coccoro Car Seat is color coded to identify use information and vehicle belt path locations for both rear-facing and forward-facing use.

- Rear-facing information on the car seat is highlighted in blue.
- Forward-facing information on the car seat is highlighted in red.

### **Rear-facing Use - Infants 33 lbs. (15 kg), 36 inches (91 cm) or less:**

#### **⚠️ WARNING - DEATH or SERIOUS INJURY can occur**

- **For proper harness fit and crash protection:**
  - **Shoulder harness slots MUST be at or below shoulder and harness MUST be snugly adjusted. Recheck for small infants.**
  - **Infant seat insert MUST be used for children less than 25 lbs. (11.4 kg).**
- **Discontinue use of the infant inserts when shoulders are above the top shoulder strap slots forward-facing or shoulder straps become too short to fit child.**

1. All infants less than one year old and 20 lbs. (9 kg) **MUST** be rear-facing.
2. Shoulder harness position:
  - a. Shoulder harness straps **MUST** be through harness slots at or below the shoulders of the infant (**fig. a**).
  - b. Any set of harness slots can be used rear-facing. To change shoulder harness slots, see "Changing Harness Position" section.
3. Infant seat insert:
  - **Must be used for children less than 25 lbs. (11.4 kg).** For installation, see "Infant Inserts" section.
  - **Discontinue use of the infant inserts when shoulders are above the top shoulder strap slots forward-facing or shoulder straps become too short to fit child.**

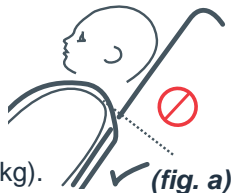

**DO NOT** use this car seat for small infants whose shoulders are below the lowest shoulder strap slots. Use an infant-only car seat which has lower shoulder strap slots.

## Forward-facing Use - Toddlers over 20 lbs. (9 kg):

### **⚠️ WARNING** - DEATH or SERIOUS INJURY can occur

- Discontinue use when child's weight exceeds 40 pounds (18 kg) or shoulders are above the top harness slots.
- Children less than one year old and 20 lbs. (9 kg) **MUST** use this car seat rear-facing. Serious crippling injury or death can result if infant faces front of vehicle.
- LATCH or vehicle seat belt **MUST** be routed through forward-facing belt path when using car seat forward-facing.
- For proper harness fit and crash protection:
  - Infant seat insert **MUST** be used for children less than 25 lbs. (11.4 kg).
- Discontinue use of the infant inserts when shoulders are above the top shoulder strap slots forward-facing or shoulder straps become too short to fit child.

#### 1. Shoulder harness position:

- a. Shoulder harness **MUST** be through harness slots at or above shoulders of child (**fig. b**).
- b. Use only the 3rd set or top set of harness slots forward-facing (**fig. c**).

#### 2. To change shoulder harness slots, see "Changing Harness Position" section.

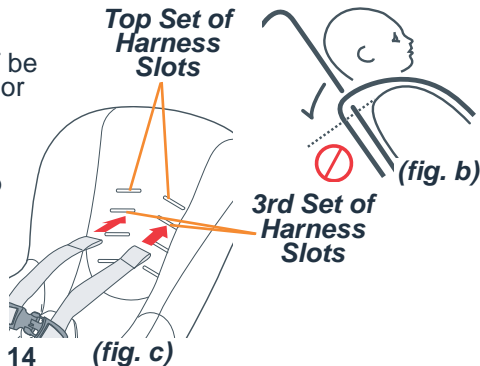

## Section 8 - Selecting A Vehicle Seating Location

**⚠️ WARNING** - DEATH or SERIOUS INJURY can occur

- **DO NOT** use this child restraint rear-facing in a vehicle front seating location with an air bag. Child's head and neck may be seriously injured when an inflating air bag hits back of child restraint.
- **Never** put a car seat in a vehicle front seating location unless recommended in vehicle owner's manual.

**⚠️ WARNING** - The safest place for your child is in the rear seat.

- **The National Highway Traffic Safety Administration (NHTSA)** alerts vehicle owners that according to accident statistics, children 12 and under are safer when properly restrained in the rear seating positions rather than the front seating positions.

**1** Refer to vehicle owner's manual for car seat installation instructions for your vehicle.

- Use car seat in a rear vehicle seat location whenever possible.
- Never use a car seat in a front seat location unless recommended in vehicle owner's manual.





- For vehicles with air bags, always follow child restraint installation information provided in vehicle owner's manual.

DO NOT use car seat rear-facing on front seat with an air bag.

For a toddler over one year old and forward-facing, if a vehicle front seat location with an air bag must be used, follow the vehicle manufacturer's instructions for child restraint use and move the vehicle seat back as far as possible.

	<p><b>DO NOT</b> place rear-facing child seat on front seat with air bag. <b>DEATH OR SERIOUS INJURY</b> can occur.</p> <p>The back seat is the safest place for children 12 and under.</p>	<b>▲</b> WARNING <b>▲</b>
<p>NO coloque el asiento infantil para el automóvil orientado hacia atrás en el asiento delantero del vehículo que tiene una bolsa neumática de seguridad. El niño podría MORIR O SUFRIR LESIONES GRAVES. El asiento trasero es el lugar más seguro para los niños de 12 años o menores.</p>		

## 2 Vehicle seats:

DO NOT use this Car Seat on the following types of vehicle seats:



**Seats Which Face  
Rear Of Vehicle**



**Seats Which Face  
Sides Of Vehicle**

## Options For Securing A Car Seat:

This car seat can be secured to a vehicle using the LATCH System or a vehicle seat belt.

### 1. LATCH System:

**LATCH** stands for **L**ower **A**nchors and **T**ethers for **C**hildren.

Model year 2003 and newer vehicles are equipped with LATCH Anchorage Systems. Check vehicle owner's manual to determine if your vehicle has the LATCH Anchorage System. Look for LATCH system symbol (*fig. a*) or the LATCH Lower Anchor symbol (*fig. b*).

Some vehicle owner's manuals may identify the LATCH System as "ISOFIX". An ISOFIX System can be used in the same way as the LATCH System.

If your vehicle has the LATCH System, the LATCH System including top tether should be used whenever possible.



(*fig. a*)



(*fig. b*)

### 2. Vehicle Seat Belt and Top Tether Strap:

If your vehicle does not have the LATCH System, the car seat **MUST** be secured to the vehicle using a vehicle seat belt and top tether strap as required.

Check vehicle owner's manual for seating locations recommended for car seat use and location of top tether anchorages.

**NOTE:** Tether strap should always be used when a tether anchor is available. Tether strap use is recommended for rear-facing when possible.

## **Top Tether Information:**

- If a top tether anchor is not available in your vehicle, the car seat **MUST** be secured with only the vehicle seat belt until a top tether anchor can be installed.
- For those passenger vehicles or buses where top tether anchors are not available, the car seat may be used without the top tether provided a secure installation can be achieved.

**NOTE:** Top tether use is recommended for rear-facing when possible.

- When not in use, store top tether in pocket at top of seat back (**fig. c.**).

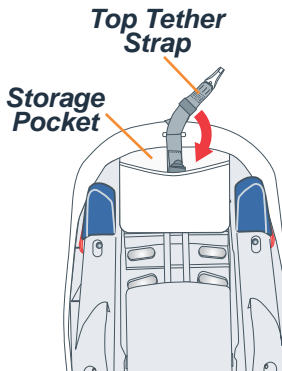

**(fig. c)**

## Section 9 - LATCH System

### LATCH System On This Car Seat:

The LATCH System on the Coccoro Car Seat consists of a lower anchor belt (1) with push-on connectors (2) and a top tether strap with tether hook (3) (fig. a & b).

### Securing Car Seat To Vehicle:

#### Forward-Facing:

The lower anchor belt push-on connectors (2) and top tether hook (3) on the car seat connect to the LATCH Anchorage System in a vehicle.

#### Rear-Facing:

The lower anchor belt push-on connectors (2) connect to the LATCH Anchorage System lower anchors and top tether hook (3) connects to the tether attachment strap (4) (fig. c).

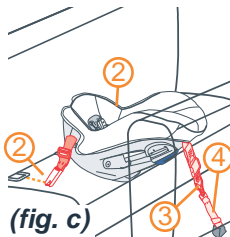
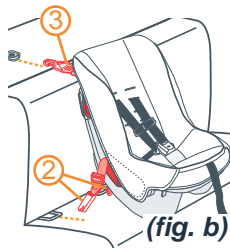
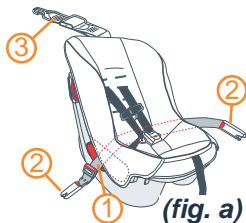

## **LATCH Anchorage System In Vehicles:**

Child restraint anchorage system or LATCH System in the vehicle consists of two lower anchors (4) located at the vehicle seat bight (5) and a top tether anchor (6) (fig. d). Refer to vehicle owner's manual for seating locations which have the LATCH Anchorage System. Information regarding the LATCH system may be identified by the LATCH System symbol (fig. e).

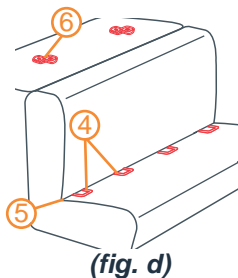

(fig. d)

Lower anchors may not be visible in some vehicles. Lower anchors that are not visible are located below a solid color round dot on the vehicle upholstery or a round dot with a picture of a car seat in the center as shown in fig. f.

The vehicle manufacturer may provide funnel guides to separate the vehicle seat cushions providing easier access to the lower anchorage. See vehicle owner's manual.



(fig. e)

Rear center seating position:

LATCH Anchorages with 11 inch (280 mm) spacing may not be available in your vehicle in the rear center seating position. If use of the rear center position is preferred, use the vehicle seat belt to secure the car seat. See "Rear-facing or Forward-facing Installation With Vehicle Seat Belt" section.



(fig. f)

## Section 10 - Rear-facing Installation

### **WARNING** - DEATH or SERIOUS INJURY can occur

- **DO NOT** use this car seat rear-facing in a vehicle front seating location with an air bag.
- Rear-facing car seat must be properly reclined:
  - Too reclined can result in injury or ejection.
  - Too upright can result in breathing difficulties.
- For proper harness fit and crash protection:
  - Infant seat insert **MUST** be used for children less than 25 lbs. (11.4 kg).
  - Discontinue use of the infant inserts when shoulders are above the top shoulder strap slots forward-facing or shoulder straps become too short to fit child.

## 10a. Rear-facing Installation With LATCH

### **⚠️ WARNING** - DEATH or SERIOUS INJURY can occur

- LATCH or vehicle seat belt **MUST** be routed through rear-facing belt path when using car seat rear-facing.
- LATCH belt **MUST** stay tightly adjusted around car seat at all times.
- Only use the car seat LATCH System in vehicle seating locations designated by the vehicle manufacturer for use with LATCH and that have an anchor spacing of 11 inches (280 mm).
- LATCH connectors must be secured to the vehicle LATCH anchors only. Connection to other vehicle anchors or vehicle components could result in the anchor tearing free in a crash.
- Never attach more than one hook-on connector to a vehicle lower anchor unless recommended by the vehicle owner's manual for that vehicle.
- Always use rear-facing tether whenever possible.

- 1 Refer to vehicle owner's manual to identify the seating locations with LATCH Anchorage System. Select the seating location to be used and locate the vehicle lower anchors at the seat bight (*fig. a*) for that seating location. Location of some vehicle lower anchors will be identified by the symbol in (*fig. b*).

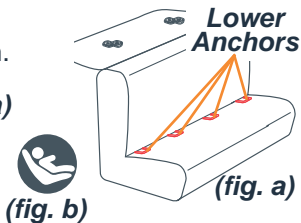

**2** After selecting a seating location, if vehicle seat back is adjustable, adjust seat back into most upright position or the position specified in the vehicle owner's manual.

**3** Remove LATCH lower anchor belt from the LATCH storage pocket on right side of the seat pad.

- Lengthen lower anchor belt by pressing adjuster release button while pulling belt to extend the length of lower anchor belt (**fig. c**).

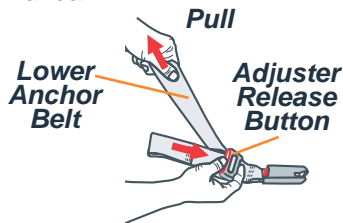

(fig. c)

**4** Place the LATCH lower anchor belt into the rear-facing belt path.

- Lift and fold front of seat pad back into car seat to access belt path by unsnapping front and unhooking sides of pad (**fig. d**).
- With LATCH connector slot on the bottom and red release button on side away from car seat, place lower anchor belt into rear-facing belt path under arms, pulling forward into belt path location identified with the blue "Lap Belt or LATCH Here" arrows.
- Center lower anchor belt and check that it is not twisted.
- Pull front of seat pad forward, lower down and secure in place.

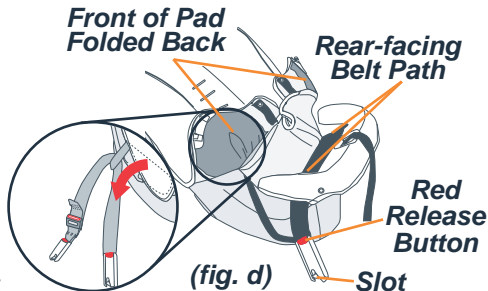

(fig. d)



**5** Place car seat rear-facing in the vehicle seat location selected with rear-facing belt path toward vehicle seat back and centered between the vehicle lower anchors (*fig. e*).

**6** Connect lower anchor connectors to vehicle lower anchors.

- Position red release button of Push-On Connector facing away from car seat and wording on back side of connector facing car seat. If connector is not in this position, turn connector over.
- Position the slot of the Push-On Connector onto the vehicle anchorage. Push connector in to lock onto the vehicle anchorage **①** (*fig. f*). You should hear a click.
- Pull on connector to be sure it is locked onto the anchorage **②**.
- Repeat for connector on opposite side.

**7** Tighten lower anchor belt to secure the car seat.

- Press down in center of car seat to depress the vehicle cushion and pull free end of lower anchor belt to tighten belt (*fig. g*).

**8** Adjust recline of car seat.

- To properly recline seat back, position car seat so reference line is horizontal (*fig. h*).

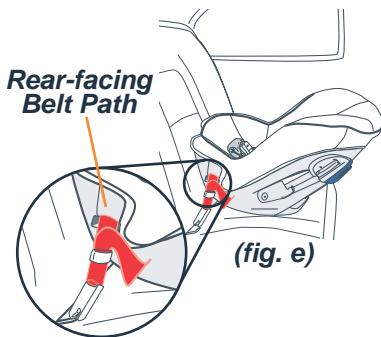

(*fig. e*)

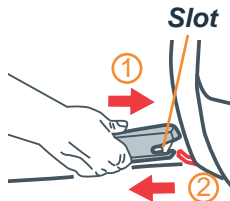

(*fig. f*)

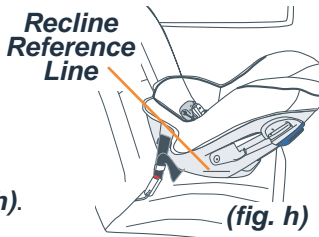

(*fig. h*)

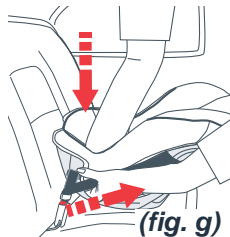

(*fig. g*)

- 9 Check recline angle of car seat. Recline reference line on side of seat **MUST** be horizontal (*fig. j*). If recline reference line is not horizontal, readjust or place tightly rolled up towel, blanket or firm foam (pool noodle) under end of car seat base contacting vehicle seat back (*fig. j*).

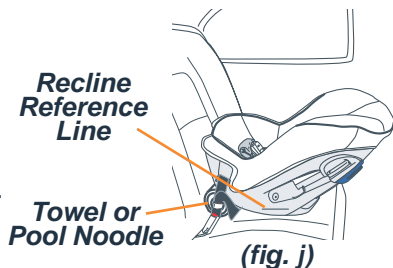

If car seat cannot be adjusted to make line horizontal:

1. Try a different LATCH equipped seating position.
2. Try installing using the vehicle seat belt. See “Rear-facing Installation With Vehicle Seat Belt” section.
3. Do not use this car seat.

**NOTE:** Vehicle must be parked on horizontal surface and child in car seat when checking recline angle of car seat.

- 10 Secure tether attachment strap if possible. See “Tether Attachment Strap Installation” section (*fig. k*).

- 11 Attach tether to tether attachment strap if possible and adjust tether to remove slack.

- 12 Check for secure installation. Gripping car seat at top of armrest, pull car seat front to back and left to right to check for secure installation (*fig. k*). LATCH belt **MUST** stay tight and child restraint should not move more than 1 inch in any direction.

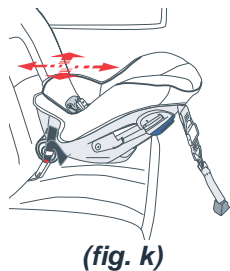

- If LATCH belt does not stay tight or car seat cannot be securely installed, try a different LATCH location or use the vehicle’s seat belt to secure the car seat.

Recheck recline angle of car seat. Adjust if necessary.

- 13 Re-snap and re-hook pad cover onto car seat.

## **Removal Of Car Seat Installed With LATCH:**

- 1** Unhook tether:
  - To loosen tether - tip tether strap adjuster and pull to loosen tether strap.
  - To remove tether hook - depress retainer spring and unhook tether hook from attachment strap (**fig. l**).
- 2** Loosen lower anchor belt by pressing adjuster button and pulling out lower anchor belt (**fig. m**).
  - Pressing down in center of car seat to reduce tension on lower anchor belt will make it easier to loosen lower anchor belt.
- 3** Remove push-on connectors from vehicle anchors.
  - Press and hold red release button **①**.
  - Pull the connector off the vehicle anchorage bar **②** (**fig. n**).
  - Repeat to remove push-on connector on opposite side.

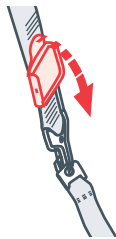

(fig. l)

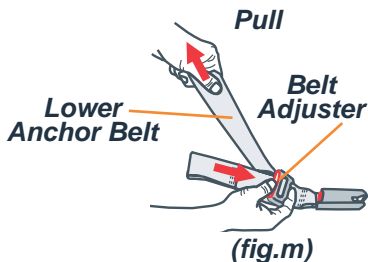

(fig.m)

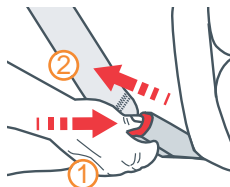

(fig. n)

## **Storage Of Lower Anchor Belt And Connectors:**

When not using the LATCH System, store the lower anchor belt and push-on connectors by removing lower anchor belt and connectors from rear-facing belt path and store in pocket on right side of car seat underneath seat pad (**fig. p**).

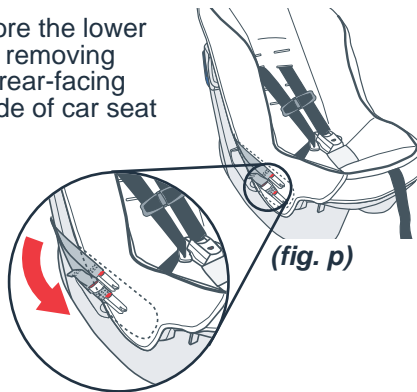

## **Top Tether Storage:**

When not using top tether, store top tether in pocket at top of seat back (**fig. q**).

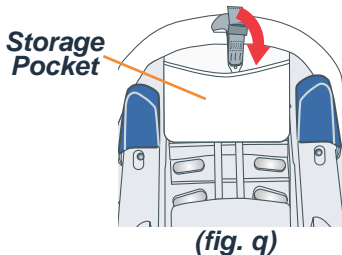

## **10b. Rear-facing Installation With Vehicle Seat Belt**

### **⚠️ WARNING - DEATH or SERIOUS INJURY can occur**

- **DO NOT** use this car seat rear-facing in a vehicle front seating location with an air bag.
- **LATCH** or vehicle seat belt **MUST** be routed through rear-facing belt path when using car seat rear-facing. Use tether when possible.
- Rear-facing car seat must be properly reclined:
  - Too reclined can result in injury or ejection.
  - Too upright can result in breathing difficulties.
- Not all vehicle seat belts can be used with this car seat. Read vehicle owner's manual and "Vehicle Seat Belts" section in this manual.
- Vehicle seat belt **MUST** stay tightly adjusted around car seat at all times. If vehicle seat belt does not stay tight, read the vehicle owner's manual and "Vehicle Seat Belts" section in this manual.

- 1 Refer to vehicle owner's manual to identify the seating locations which can be used with a car seat. Check for specific instructions for car seat use.
- 2 After selecting a seating location, if vehicle seat back is adjustable, adjust seat back into most upright position or position specified in vehicle owner's manual.
- 3 Store tether in storage pocket in pocket at top of seat back and store LATCH lower anchor belt in pocket on side of seat. See "Installation with LATCH" section.
- 4 Place car seat rear-facing in the vehicle seat location selected with rear-facing belt path toward vehicle seat back (**fig. a**).

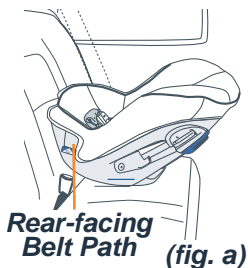

- 5 Adjust recline of car seat.
  - To properly recline seat back, position car seat so reference line is horizontal (**fig. b**).

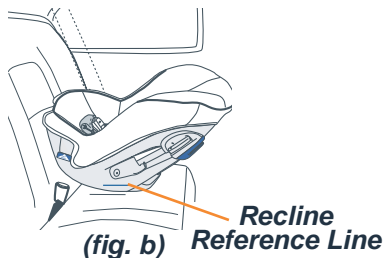

**6** Place the vehicle lap belt into the rear-facing belt path.

- Lift and fold front of seat pad back into car seat to access belt path by unsnapping front and unhooking sides of pad (**fig. c**).
- Place vehicle lap belt into rear-facing belt path under arms and make sure the lap belt is not twisted (**fig. c**).

**NOTE:** For installation with a vehicle lap and shoulder belt - place vehicle lap belt into rear-facing belt path under arms and shoulder belt outside of seat, against the vehicle seat back (**fig. d**).

- Pull lap belt into belt path location identified with the blue “Lap Belt or LATCH Here” arrows.
- Buckle vehicle seat belt and tighten lap belt to remove any slack.

**7** Tighten vehicle seat belt to secure the car seat.

- Press down in center of car seat to depress the vehicle cushion while tightening the vehicle lap belt (**fig. e**).

**Note:** For installation with vehicle lap and shoulder belt - if the vehicle lap belt does not remain tightly adjusted around the car seat a rear-facing belt lock-off may be required to lock the vehicle lap belt. See “Rear-facing Belt Lock-off” section.

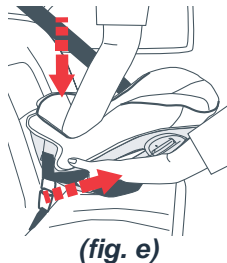
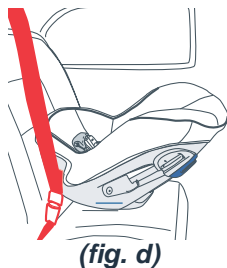
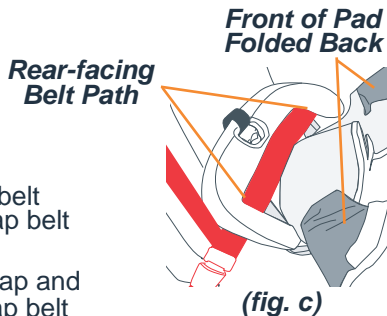

- 8** For lap and shoulder belt, place the vehicle shoulder belt around back of Coccoro with the shoulder belt on the buckle side through the lower shoulder belt guide and through the upper shoulder belt guide on the opposite side of the car seat (*fig. f and g*).

If shoulder belt is too short to go around back of Coccoro, position shoulder belt against vehicle seat back (*fig. h*).



(*fig. f*)

- 9** Check recline angle of car seat. Recline reference line on side of seat **MUST** be horizontal (*fig. j*). If recline reference line is not horizontal, readjust or place tightly rolled up towel, blanket or firm foam (pool noodle) under end of car seat base contacting vehicle seat back (*fig. j*).

If car seat cannot be adjusted to make line horizontal:

1. Try a different seating position.
2. Do not use this car seat.

**NOTE:** Vehicle must be parked on horizontal surface and child in car seat when checking recline angle of car seat.

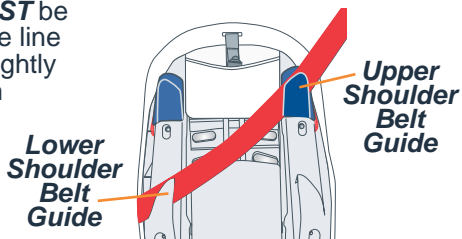

(*fig. g*)

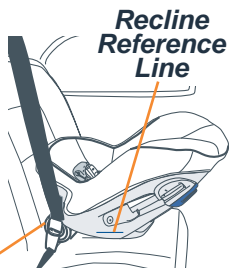

(*fig. j*)



(*fig. h*)



- 10** Secure tether attachment strap if possible. See “Tether Attachment Strap Installation” section.
- 11** Attach tether hook to tether attachment strap if possible and adjust tether to remove slack (**fig. k**).
- If tether is not used, store tether in storage pocket on back of seat. See “Tether Storage” at end of this section.

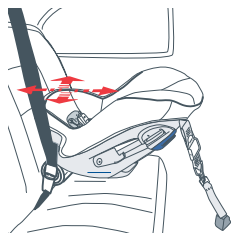

(fig. k)

- 12** Check for secure installation. Gripping car seat at top of armrest, pull car seat front to back and left to right to check for secure installation (**fig. k**). Vehicle lap belt **MUST** stay tight.
- If vehicle lap belt does not stay tight or car seat cannot be securely installed, see vehicle owner’s manual, “Vehicle Seat Belts” section or move to a different seating location.

Recheck recline angle of car seat. Adjust if necessary (see step 6).

- 13** Re-snap and re-hook pad cover onto car seat.

## **Removal Of Car Seat Installed With Vehicle Seat Belt:**

### **1** Unhook tether:

- Loosen tether - tilt belt adjuster and pull tether belt to lengthen (**fig. l**).
- To remove tether hook - unhook tether hook from tether attachment strap.
- When not using top tether, store top tether in pocket at top of seat back (**fig. m**).

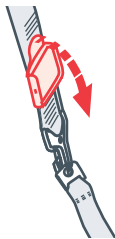

**(fig. l)**

### **2** Unbuckle vehicle seat belt.

- Pressing down in center of car seat to reduce tension on vehicle seat belt will make it easier to loosen vehicle seat belt.

### **3** Remove vehicle seat belt from belt path and shoulder belt from belt guide.

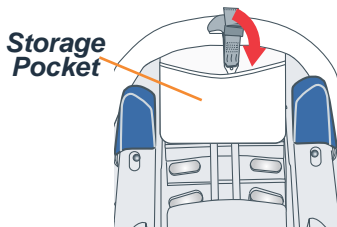

**(fig. m)**

## Section 11 - Forward-facing Installation

### **⚠️ WARNING** - DEATH or SERIOUS INJURY can occur

- For proper harness fit and crash protection:
  - Infant seat insert **MUST** be used for children less than 25 lbs. (11.4 kg).
  - Discontinue use of the infant inserts when shoulders are above the top shoulder strap slots forward-facing or shoulder straps become too short to fit child.
- Upper and lower shoulder belt guides **MUST** always contact vehicle seat back and forward-facing contact zone **MUST** always contact vehicle seat bottom for proper installation.

### **11a. Forward-facing Installation With LATCH**

### **⚠️ WARNING** - DEATH or SERIOUS INJURY can occur

- **LATCH** belt **MUST** stay tightly adjusted around car seat at all times.
- Only use the car seat **LATCH** System in vehicle seating locations designated by the vehicle manufacturer for use with **LATCH** and that have an anchor spacing of 11 inches (280 mm).
- **LATCH** connectors must be secured to the vehicle **LATCH** anchors only. Connection to other vehicle anchors or vehicle components could result in the anchor tearing free in a crash.
- Never attach more than one hook-on connector to a vehicle lower anchor unless recommended by the vehicle owner's manual for that vehicle.
- Top tether **MUST** always be used with lower anchor belt.

- 1 Refer to vehicle owner's manual to identify the seating locations with LATCH Anchorage System. Select the seating location to be used and locate the vehicle lower anchors at the seat bight (**fig. a**) for that seating location. Location of some vehicle lower anchors will be identified by the symbol in (**fig. b**).

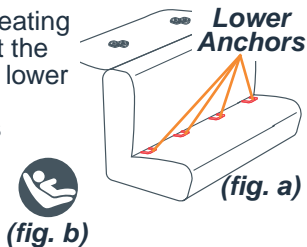

- 2 After selecting a seating location, if vehicle seat back is adjustable, adjust seat back into most upright position or the position specified in the vehicle owner's manual.

- 3 Remove LATCH Push-on connectors from the pocket on right side of the seat pad (**fig. c**).
- 4 Remove top tether from storage pocket and place in seating area of car seat.

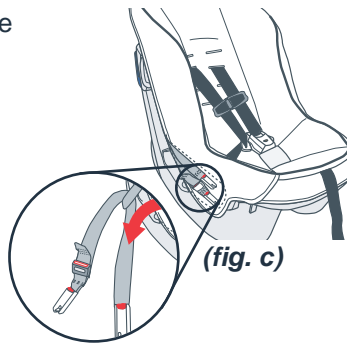

**5** Route the lower anchor belt through the forward-facing belt path identified by red “Belt Here” arrows.

- Check that LATCH belts are not wrapped around shoulder harness or harness adjuster strap.
- Lengthen lower anchor belt by pressing adjuster release button while pulling belt to extend the length of lower anchor belt (**fig. d**).
- With LATCH connector slot on the bottom and red release button toward front of car seat, route lower anchor belt through the forward-facing belt path in back of car seat. Pull through to opposite side.
- Position the lower anchor belt in the forward-facing belt path by placing the lower anchor belt between raised ribs in forward-facing belt path identified by the red “Belt Here” arrows (**fig. e**).

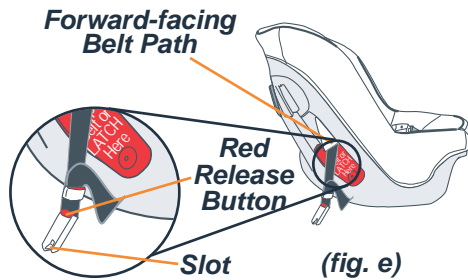
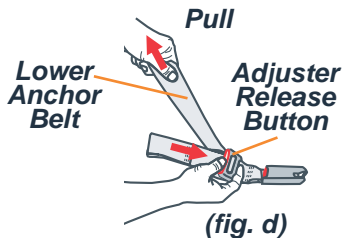

6 Place car seat forward-facing in the vehicle seat location selected with forward-facing belt path toward vehicle seat back and centered between the vehicle lower anchors (*fig. f*).

7 Position car seat so forward-facing contact zone is flat on vehicle seat bottom and seat back is in contact with vehicle seat back (*fig. f*).

8 Connect lower anchor connectors to vehicle lower anchors.

- Position red release button of Push-On Connector facing away from car seat and wording on back side of connector facing car seat. If connector is not in this position, turn connector over.
- Position the slot of the Push-On Connector onto the vehicle anchorage. Push connector in to lock onto the vehicle anchorage ① (*fig. g*). You should hear a click.
- Pull on connector to be sure it is locked onto the anchorage ②.
- Repeat for connector on opposite side.

9

Locate the tether anchor (*fig. h*) for the seating location being used.

**NOTE:** Check vehicle owners manual for tether anchor location. DO NOT use cargo tie downs or other attachment points not intended for use with car seats.

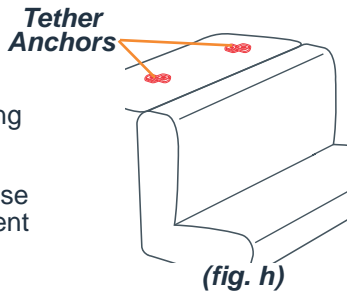
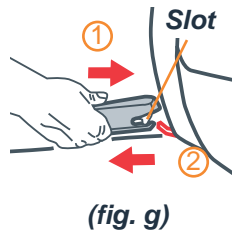
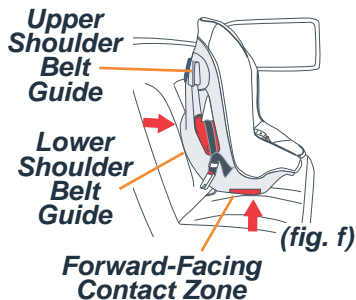

- 10** Attach tether hook **(A)** to vehicle top tether anchor hardware **(B)** (*fig. j*) and pull strap to remove slack from top tether. Check that the tether strap is not twisted. Final tightening will occur in a later step.

**NOTE:** 1. To lengthen the tether strap, tip the tether belt adjuster and pull the tether strap back through the adjuster.

2. If top tether anchor **(B)** is not available in vehicle, see vehicle owner's manual or Top Tether Information in "Selecting A Vehicle Seating Location" section.

3. Tether strap should always be used when a tether anchor is available. The top tether is used for forward-facing use.

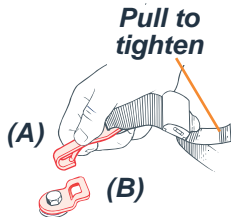

*(fig. j)*

- 11** Tighten lower anchor belt to secure the car seat.

- Press down in center of car seat to depress the vehicle cushion and pull free end of lower anchor belt to tighten belt (*fig. k*).

- 12** Snugly adjust tether strap by pulling on free end.

- 13** Check that the upper and lower shoulder belt guides are contacting the vehicle seat back and that the forward-facing contact zone is in full contact with the vehicle seat bottom (*fig. k*).

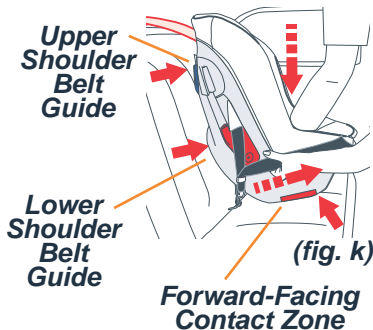

- 14** Check for secure installation. Gripping car seat at the belt path, pull car seat front to back and left to right to check for secure installation (**fig. l**). LATCH belt **MUST** stay tight.

If LATCH belt does not stay tight or car seat cannot be securely installed:

1. Try a different LATCH equipped seating position.
2. Try installing using the vehicle seat belt. See “Forward-facing Installation With Vehicle Seat Belt” section.
3. Do not use this car seat.



- 15** Re-snap and re-hook pad cover onto car seat.

**Belt Adjuster**

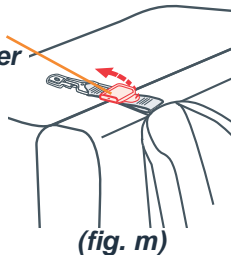

### **Removal Of Car Seat Installed With LATCH:**

- 1** Tip tether strap adjuster to loosen tether strap (**fig. m**).
- 2** Depress retainer spring **①** and unhook tether hook **②** from vehicle tether anchor (**fig. n**).
- 3** Loosen lower anchor belt by pressing adjuster button and pulling out lower anchor belt.
  - Pressing down in center of car seat to reduce tension on lower anchor belt will make it easier to loosen lower anchor belt.

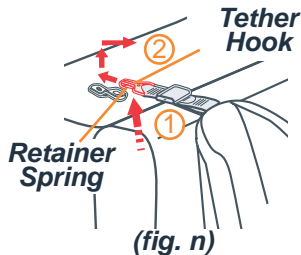



**4** Remove push-on connectors from vehicle lower anchors.

- Press and hold the red release button ①.
- Pull the connector off the vehicle anchorage bar ② (*fig. p*).
- Repeat to remove push-on connector on opposite side.

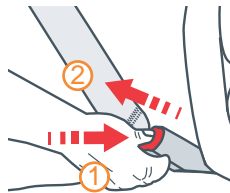

(*fig. p*)

### **Storage Of Lower Anchor Belt And Connectors:**

When not using the LATCH System, store the lower anchor belt and push-on connectors by removing lower anchor belt and connectors from forward-facing belt path and store in pocket on right side of car seat underneath seat pad (*fig. q*).

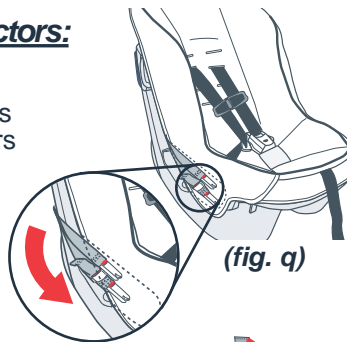

(*fig. q*)

### **Top Tether Storage:**

Store top tether in pocket on back of seat pad when not in use (*fig. r*).

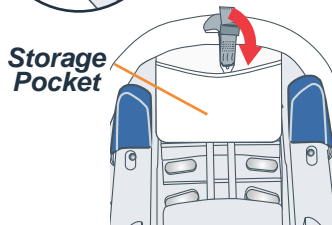

(*fig. r*)

## 11b. Forward-facing Installation With Vehicle Seat Belt

### **⚠️ WARNING** - DEATH or SERIOUS INJURY can occur

- Vehicle seat belt **MUST** stay tightly adjusted around car seat at all times.
- Top tether **MUST** be used if vehicle tether anchor is available.
- Not all vehicle seat belts can be used with this car seat. Read vehicle owner's manual and "Vehicle Seat Belts" section in this manual.
- Vehicle seat belt **MUST** stay tightly adjusted around car seat at all times. If vehicle seat belt does not stay tight, read the vehicle owner's manual and "Vehicle Seat Belts" section in this manual.

- 1 Refer to vehicle owner's manual to identify the seating locations which can be used with a car seat. Check for specific instructions for car seat use.
- 2 After selecting a seating location, if vehicle seat back is adjustable, adjust seat back into most upright position or the position specified in the vehicle owner's manual.
- 3 Remove top tether from storage pocket and place in seating area of the seat.
- 4 Place car seat forward-facing in the vehicle seat location selected with forward-facing belt path toward vehicle seat back (*fig. a*).

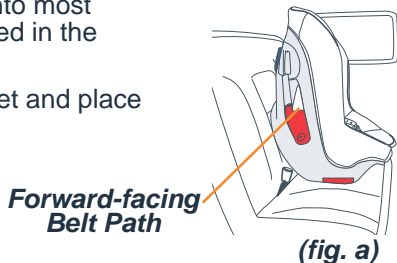

- 5 Position car seat so forward-facing contact zone is flat on vehicle seat bottom and seat back is in contact with vehicle seat back (*fig. c*).

**Forward-facing  
Belt Path**

- 6 Thread vehicle lap belt (*fig. b*) or vehicle lap and shoulder belt (*fig. c*) through the forward-facing belt path identified by the red “Belt Here” arrows and buckle seat belt.

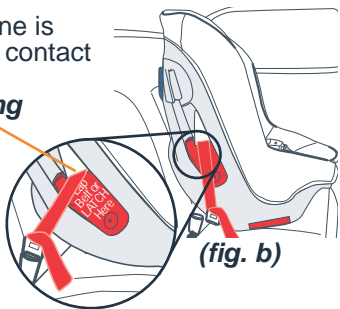

- 7 Tighten lap belt to remove all slack (*fig. c*). Final tightening will occur in a later step.

**NOTE:** For lap and shoulder belt with switchable retractor, it is acceptable but not required to switch the shoulder belt retractor into the locking mode.

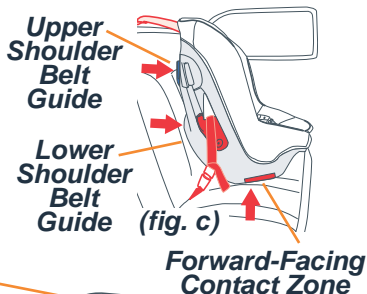

- 8 Locate the tether anchor (*fig. d*) for the seating location being used.

**NOTE:** Check vehicle owners manual for tether anchor location. DO NOT use cargo tie downs or other attachment points not intended for use with car seats.

**Tether  
Anchors**

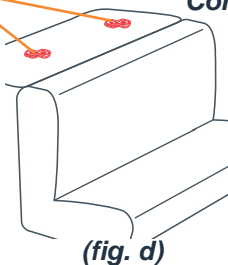

- 9 Attach tether hook (A) to vehicle top tether anchor hardware (B) (fig. e) and pull strap to remove slack from top tether. Check that the tether strap is not twisted. Final tightening will occur in a later step.

**NOTE:** 1. To lengthen the tether strap, tip the tether belt adjuster and pull the tether strap back through the adjuster.

2. If top tether anchor (B) is not available in vehicle, see vehicle owner's manual or Top Tether Information in "Selecting A Vehicle Seating Location" section.

3. Tether strap should always be used when a tether anchor is available. The top tether is used for forward-facing use.

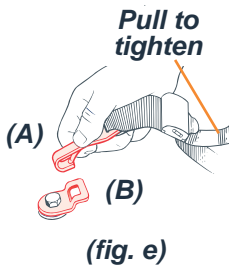

- 10 Tighten vehicle seat belt to secure the car seat.

For vehicle lap and shoulder belts:

Shoulder belt lock-off can be used to hold the vehicle seat belt tight around car seat.

- Open shoulder belt lock-off on side of car seat opposite vehicle seat belt buckle. Pull lock-off tab forward and hold open ① (fig. f).
- Slide shoulder belt up under lock-off tab ② (fig. f) and release lock-off.

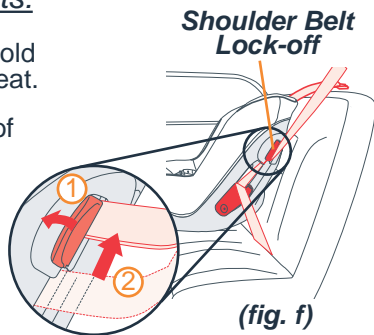

- While pressing down in center of car seat to compress the vehicle seat cushion (**fig. g**), pull on shoulder belt to tighten lap belt. Rocking the car seat from side to side will assist in getting the lap belt tightly adjusted.

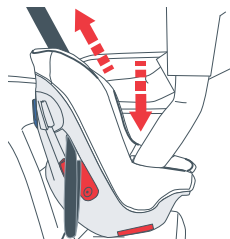

(fig. g)

For vehicle lap belt only:

- While pressing down in center of car seat to compress the vehicle seat cushion (**fig. h**), pull on free end of lap belt to tighten lap belt. Rocking the car seat from side to side will assist in getting the lap belt tightly adjusted.

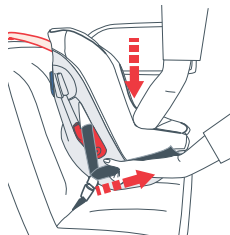

(fig. h)

**11** Snugly adjust Top Tether Strap by pulling on free end.

**12** Check that the upper and lower shoulder belt guides are contacting the vehicle seat back and that the forward-facing contact zone is in full contact with the vehicle seat bottom (**fig. j**).

**13** Check for secure installation. Gripping car seat at the belt path, pull car seat front to back and left to right to check for secure installation (**fig. j**). Vehicle lap belt **MUST** stay tight.

- If vehicle lap belt does not stay tight or car seat cannot be securely installed, see vehicle owner's manual, "Vehicle Seat Belts" section, or move to a different seating location.

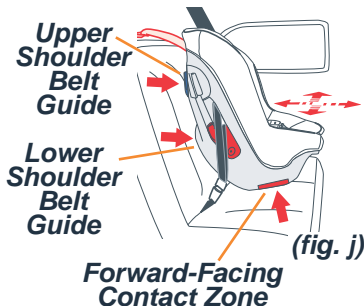

(fig. j)

## Removal Of Car Seat Installed With Vehicle Seat Belt:

- 1 Tip tether strap adjuster to loosen tether strap (*fig. k*).
- 2 Depress retainer spring ① and unhook tether hook ② from vehicle tether anchor (*fig. l*).
- 3 Unbuckle vehicle seat belt.
  - Pressing down in center of car seat to reduce tension on vehicle seat belt will make it easier to unbuckle vehicle seat belt.
- 4 For lap and shoulder belt installation, open belt lock-off and remove vehicle shoulder belt.

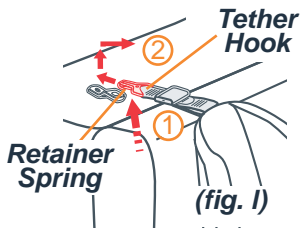
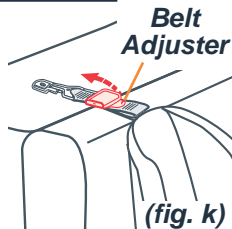

## Storage Of Lower Anchor Belt And Connectors:

When not using the LATCH System, store the lower anchor belt and push-on connectors by removing lower anchor belt and connectors from forward-facing belt path and store in pocket on right side of car seat underneath seat pad (*fig. m*).

## Top Tether Storage:

Store top tether in pocket on back of seat pad when not in use (*fig. n*).

**Storage Pocket**

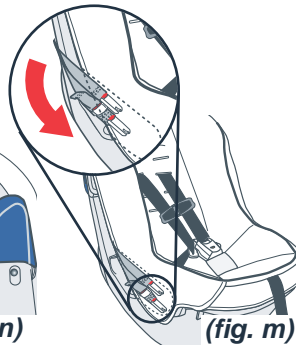
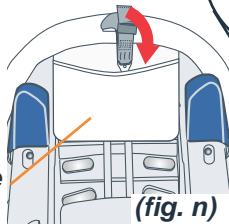

## Section 12 - Securing Child In Car Seat

### **WARNING** - DEATH or SERIOUS INJURY can occur

- **Keep harness straps snug and positioned on shoulders and thighs.**
- **For rear-facing, shoulder harness slots MUST be at or below shoulder and harness MUST be snugly adjusted. Recheck for small infants.**
- **Infant seat insert MUST be used for children less than 25 lbs. (11.4 kg).**
- **Discontinue use of the infant inserts when shoulders are above the top shoulder strap slots forward-facing or shoulder straps become too short to fit child.**
- **Discontinue use of car seat if shoulders are above top shoulder harness slots when forward-facing.**
- **Child must be dressed in clothing with arms and legs that will not interfere with buckling and snugly adjusting harness.**
- **Do not use accessories or parts other than those provided by Combi USA. Use of accessories or parts from other manufacturers could alter the performance of the car seat.**
- **Never leave child unattended, even when sleeping.**
- **Strangulation Hazard: Child can strangle in loose harness straps. Never leave child in car seat when straps are loose or unbuckled.**

**1** Check position of harness:

**⚠ WARNING - DEATH or SERIOUS INJURY can occur**

- **DO NOT use this car seat if infant's shoulders are below lowest slots when rear-facing.**

• **Rear-facing**

- Shoulder harness straps must be through harness slots at or below child's shoulders (*fig. a*).

See "Changing Shoulder Harness Position" section to change position of shoulder harness straps.

- Infant seat insert **MUST** be used for children less than 25 lbs. (11.4 kg).
- Discontinue use of the infant inserts when shoulders are above the top shoulder strap slots forward-facing or shoulder straps become too short to fit child.

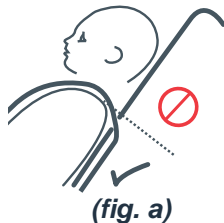



## • Forward-facing

- Shoulder harness straps must be at or above child's shoulders (**fig. b**).
- Only use the 3rd set or top set of harness slots forward-facing (**fig. c**).
- Discontinue forward-facing use of car seat if shoulders of child are above top harness slots.

See "Changing Shoulder Harness Position" section to change position of shoulder harness straps.

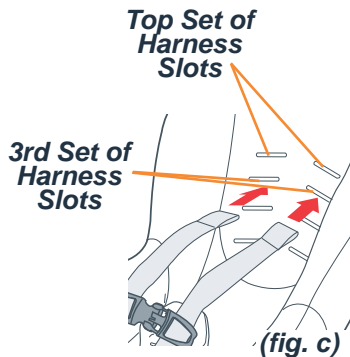
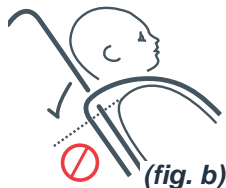

**⚠ WARNING** - DEATH or SERIOUS INJURY can occur

- Discontinue use when child's shoulders are above top slots forward-facing.

**2** Loosen harness:

- While pressing on harness adjuster **1**, pull out on shoulder harness strap **2** (*fig. d*).

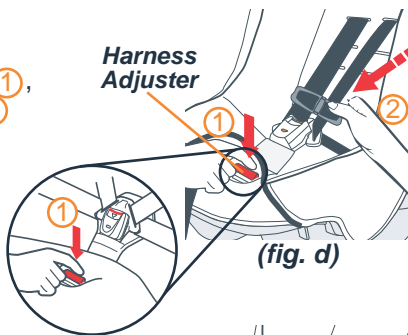

**3** Unbuckle harness and place buckle tongues in tongue storage loops on sides of seat (*fig. e*).

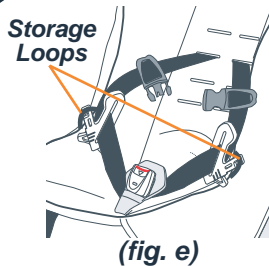

**4** Place child in car seat with back and rump contacting seating surfaces (*fig. f*).

**5** Place harness straps over child's shoulders and thighs.



- 6** Buckle Harness:
- Place top of buckle tongues together **①** and insert buckle tongues into buckle **②** (**fig. g**). You should hear a click.
  - Pull up on tongues to be sure they are locked.

**NOTE:** A green indicator will appear in the window below the buckle release button when tongues are locked in the buckle and a red indicator will appear in the window below the buckle release button when the tongues are not locked in the buckle.

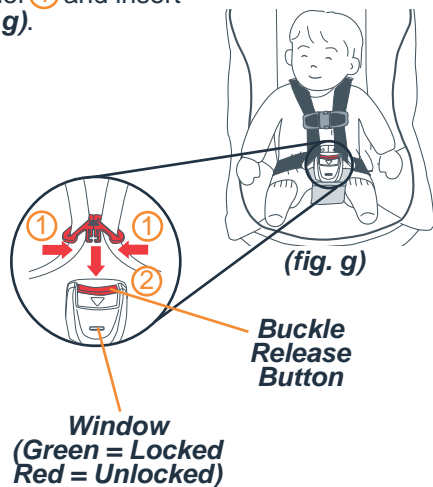

- 7** Pull harness adjuster strap (**fig. h**) to snugly adjust harness straps so that shoulder belt webbing cannot be pinched with fingers to fold webbing (**fig. j** and **k**).

- Check that harness straps are snug on shoulders and thighs.
- A snug strap should not allow any slack. It lies in a relatively straight line without sagging. It does not press on the child's flesh or push the child's body into an unnatural position.

**NOTE:** If harness cannot be snugly adjusted as described above, do not use this car seat.

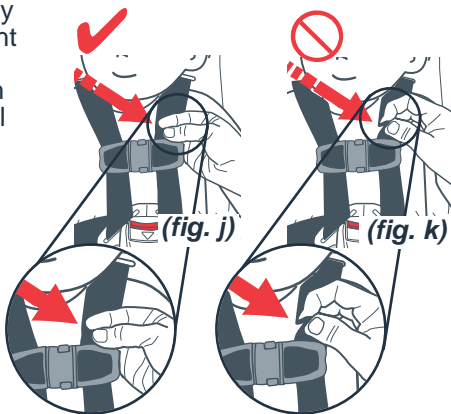
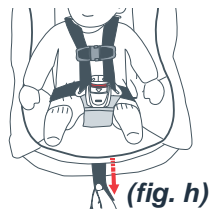

- 8** Close chest clip and position chest clip at arm pit level (**fig. l**).

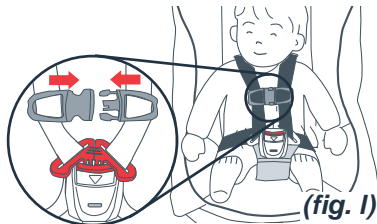

## Section 13 - Operation and Adjustments

### 13a. Harness Use and Adjustment

**⚠ WARNING** - DEATH or SERIOUS INJURY can occur

- Harness **MUST** be snugly adjusted around child.

#### 1 Tru-Safe Buckle Operation:

- To buckle:
  - Place top of buckle tongues together ① and insert buckle tongues into buckle ② (fig. a).
  - Pull up on tongues to be sure they are locked.

**NOTE:** A green indicator will appear in the window below the buckle release button when tongues are locked in the buckle.

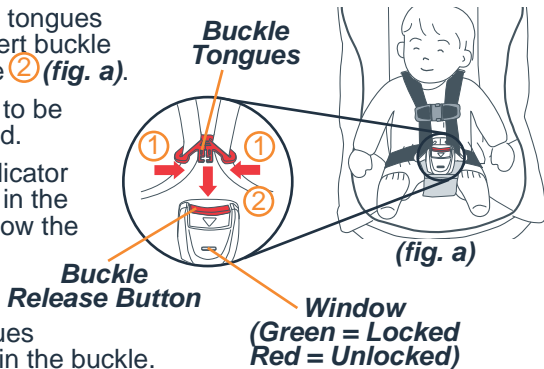

- To unbuckle:
  - Press red buckle release button and pull buckle tongues out of buckle.

**NOTE:** A red indicator will appear in the window below the buckle release button when the tongues are not locked in the buckle.

## 2 Harness Strap Adjustment

- To tighten shoulder harness straps:
  - Pull harness adjuster strap (**fig. b**).
  - Check that straps are snug on shoulders and thighs. Shoulder belt webbing should not fold when pinched between fingers (**fig. c** and **d**).
  - Position chest clip at armpit level.

If the harness cannot be adjusted small enough, switch the metal harness plate to the upper sewn loops on shoulder harness straps. See “Harness Use and Adjustment” section.

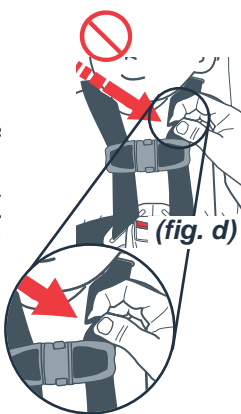
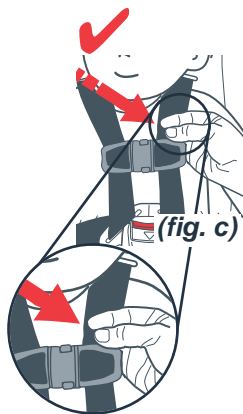

- To loosen shoulder harness straps:
  - Grasp shoulder harness strap.
  - While pressing on harness adjuster, pull down on shoulder harness straps (**fig. e**).

If the harness cannot be adjusted large enough, switch the metal harness plate to the lower sewn loops on shoulder harness straps. See “Harness Use and Adjustment” section.

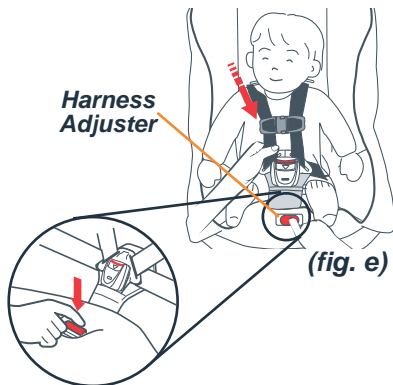

### 3 Chest Clip Operation:

- To open:
  - Press tabs ① and pull apart ②.
- To close:
  - Snap halves together.
  - Make sure chest clip is locked by pulling out.
  - Position chest clip at arm pit level.

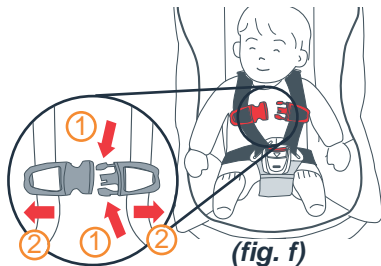

### 4 Harness Strap Covers:

Use of the included harness strap covers is optional.

- To remove:
  - Remove the shoulder harness straps from the seat back. See “Removal of Shoulder Harness Straps” section.
  - Pull the harness strap covers off the shoulder harness straps (*fig. g*).
  - Reassemble the shoulder harness straps into the seat back. See “Reassembly of Shoulder Harness Straps and Harness Cover” section.
- To remove:
  - Remove the shoulder harness straps from the seat back. See “Removal of Shoulder Harness Straps” section.
  - Thread one shoulder harness strap through each harness strap cover (*fig. h*).
  - Reassemble the shoulder harness straps into the seat back. See “Reassembly of Shoulder Harness Straps and Harness Cover” section.

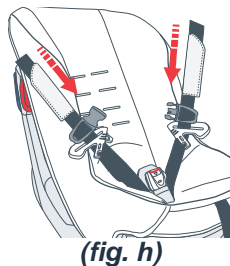
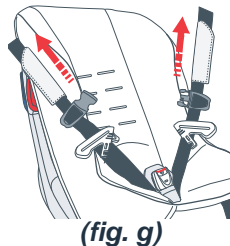



## 13b. Changing Harness Slot Positions

### •Rear-facing

- Shoulder harness straps *must* be through harness slots at or *just below* child's shoulders (**fig. j**).

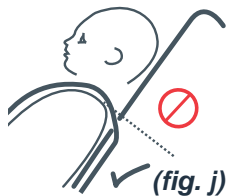

### •Forward-facing

- Shoulder harness straps *must* be at or *above* shoulders (**fig. k**).
- Only use the 3rd set or top set of harness slots forward-facing (**fig. l**).
- Discontinue use of car seat if child's shoulders are above top harness slots.

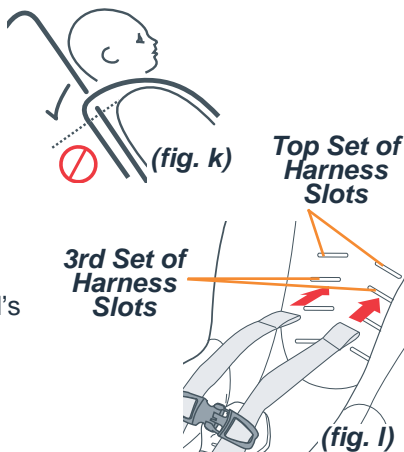

**⚠ WARNING** - DEATH or SERIOUS INJURY can occur

- Use only 3rd set or top set of harness slots forward-facing.

# 1 Removal of shoulder harness straps:

1. Release buckle and unbuckle chest clip.
2. Removal of shoulder harness straps.
  - a. Lengthen shoulder harness straps to maximum length.
    - From front of car seat, grasp harness strap (**fig. m**).
    - While pressing down on harness adjuster (**fig. m**), pull harness straps out as far as possible.
  - b. Remove harness shield from back of car seat (**fig. n**).
    - Pull tabs on both sides of harness cover out of slots in car seat.

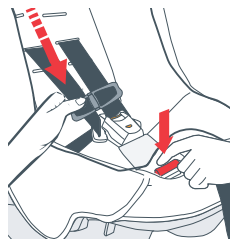

(fig. m)

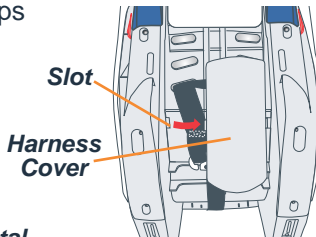

(fig. n)

- c. Remove loops at ends of both shoulder harness straps from metal harness plate (**fig. p**)
- d. From front of car seat, pull shoulder harness straps out of seat and seat pad (**fig. q**).

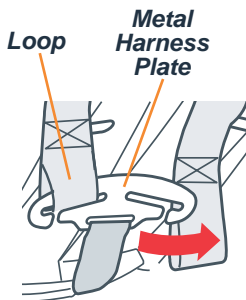

57

(fig. p)

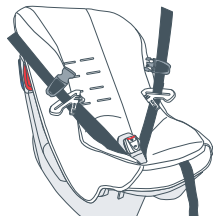

(fig. q)

## 2 Reassembly of shoulder harness straps:

### **⚠️ WARNING** - DEATH or SERIOUS INJURY can occur

- To prevent ejection in a crash, the sewn loops on the shoulder harness straps **MUST** be properly attached to the metal harness plate.
- To prevent loose harness and risk of ejection, harness shield **MUST** be in place during use.
- To prevent slack in harness and potential ejection in a crash, the shoulder harness straps must be routed through harness slots at the same height in the pad and seat back.

Attachment of shoulder harness straps.

1. Pull out on shoulder harness strap to make sure it is not twisted.
2. Slide end of shoulder harness strap through harness slots at required height in seat pad, foam, and seat back (*fig. r*). Pull all excess strap through seat back.
3. Repeat for other shoulder harness strap.

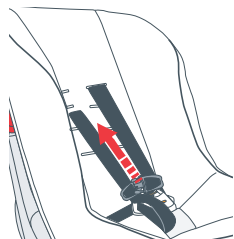

(fig. r)

4. Select loops on shoulder harness straps to be used.
  - Use the upper loops for smaller children.
  - Use the lower loops for larger children.
5. Connect loop on shoulder harness straps to metal harness plate.
  - a. Pull metal harness plate out and make sure harness adjuster strap is not twisted.

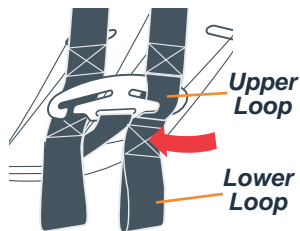

(fig. s)

- b. Pull right shoulder harness strap out and slide entire sewn loop into slot on right side of metal harness plate (fig. s) and (fig. t).
- c. Repeat for left shoulder harness strap.

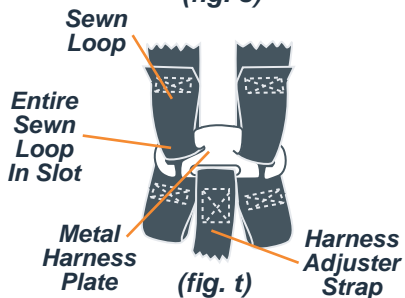

(fig. t)

**NOTE:** Make sure that the sewn loops are completely within the slots of the metal harness plate (fig. u) and that the shoulder harness straps are not twisted.

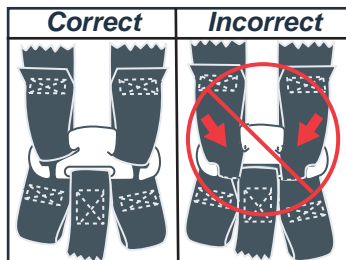

(fig. u)

6. Pull harness adjuster strap located at front of seat to tighten the harness. Verify proper operation, tightening, and that belts are not twisted.

7. Replace harness shield on back of car seat  
(*fig. v*).

- Slide tabs on sides of harness cover into slots in back of car seat.

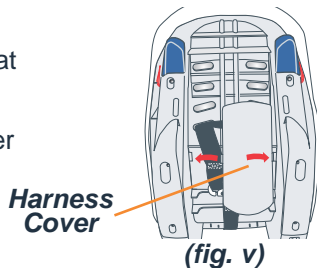

**⚠ WARNING - DEATH or SERIOUS INJURY can occur**

- **Shoulder harness cover MUST be placed over harness straps and properly secured at both sides.**
- **To prevent loose harness and risk of ejection, shoulder harness cover MUST be in place during use.**

Reassembly of shoulder harness straps and harness cover is now complete.

### 13c. Infant Inserts

## **⚠️ WARNING** - DEATH or SERIOUS INJURY can occur

- For proper harness fit and crash protection:
  - Infant seat insert **MUST** be used for children less than 25 lbs. (11.4 kg).
  - Discontinue use of the infant inserts when shoulders are above the top shoulder strap slots forward-facing or shoulder straps become too short to fit child.

#### To remove infant head insert:

1. On back side of car seat, untie strings securing the head insert.
2. From front side pull infant head insert out of seat and strings out of shoulder belt slots.

#### To remove infant seat insert:

1. With shoulder harness straps unbuckled, lift seat insert out from under harness belts and out of seat.

#### To install infant inserts:

1. Install seat insert first. Unbuckle shoulder harness belts and slide seat insert into seat with lap belt in openings on sides and crotch belt opening at front of seat insert (**fig. w**).
2. Secure infant head insert above the seat insert by sliding strings through one of the top two shoulder belt slots and secure by tying the strings on the back side of the car seat (**fig. x**).

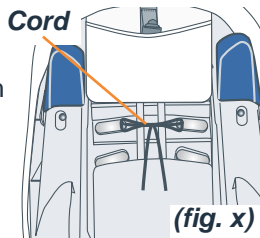
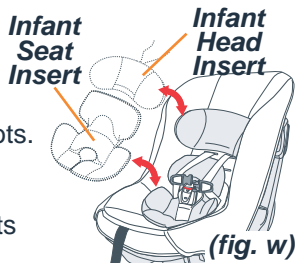

### **13d. Rear-facing Tether Attachment Strap Installation**

**⚠ WARNING - DEATH or SERIOUS INJURY can occur**

- **Only use Tether Attachment Strap for rear-facing tether installation.**
- **Always use rear-facing tether whenever possible.**

Use the Tether Attachment Strap to create a tether anchor point for use with the car seat rear-facing. The Tether Attachment Strap must be installed at the base of the vehicle seat in front of the rear-facing car seat. In vehicles where available locations for tether anchor point are too large to wrap the Tether Attachment Strap around, the rear-facing tether cannot be used. Store tether in storage pouch on back of car seat.

#### **Tether Attachment Strap Installation:**

1. Locate the Tether Attachment Strap stored in the pouch on the back of the car seat.
2. Move vehicle seat forward if necessary to expose to the vehicle seat track and other vehicle mounting hardware (closest to the center of the vehicle). Select a fixed location on the inboard vehicle seat track or other mounting structure that is bolted to the floor of the vehicle and that the Tether Attachment Strap can be wrapped around and secured to. If a location is not easily identified, contact the vehicle manufacturer for a suggested location to secure the Tether Attachment Strap.

3. Slide the metal plate ① of the Tether Attachment Strap under the vehicle seat track or structure ② (*fig. y*).

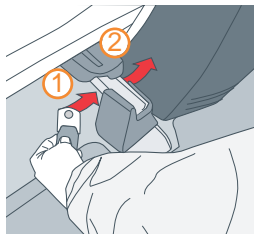

(*fig. y*)

4. Slide the metal plate through the sewn loop ③ (*fig. z*).

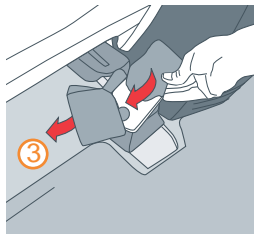

(*fig. z*)

5. Pull on the metal plate ④ to tighten the Tether Attachment Strap in place (*fig. aa*).

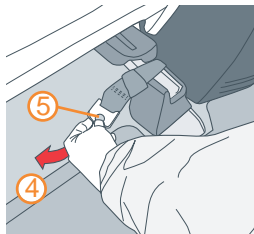

(*fig. aa*)

6. Use round hole ⑤ in metal plate as the tether attachment point for rear-facing installation.



## Section 14 - Vehicle Seat Belts

Design and operation of vehicle seat belt systems vary from vehicle to vehicle and from seating location to seating location in the same vehicle. Not all vehicle seat belts can be used with a child restraint. Refer to this section for information on the various types of vehicle seat belt systems.

**⚠ WARNING - DEATH or SERIOUS INJURY can occur**

- **Not all vehicle seat belts can be used with a car seat. The car seat must be held tightly at all times by a lap belt (or lap belt portion of a lap/shoulder belt) that will not loosen while driving.**

### **To provide a secure installation of the car seat:**

- Read the vehicle owner's manual regarding securing a car seat and vehicle seat belt use with car seat.
- Follow all instruction labels on vehicle seat belt and car seat.

If car seat does not stay tightly secured after following instructions in this manual, vehicle owner's manual, and vehicle seat belt labels:

- Move car seat to another seating location and try again, or
- Contact vehicle dealer for assistance and seat belt modification parts, when available.
- See "Need Help Installing Your Car Seat" in "Proper Use Checklist" section.

## Belts Forward of Seat Bight

Vehicle seat belts located forward of seat bight (**fig. a & b**) may not securely hold car seat. Check vehicle owner's manual or see vehicle dealer for car seat installation requirements.

- *If seating position is approved for use with car seat, install car seat and check for secure installation by pulling car seat front to back and side to side. If car seat slides forward or vehicle seat belt does not stay tight, DO NOT use these seat belts.*

**Belt Forward of Seat Bight**

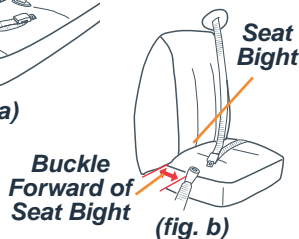
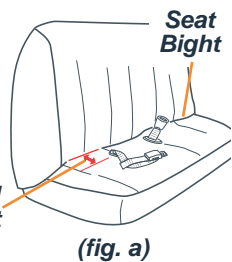

## Lap Belts - Manually Adjustable

Manually adjustable lap belts (**fig. c**) normally will hold a car seat tightly. However, in some cases, the locking latch plate on some seat belts may slip and loosen if positioned at a certain angle. If this happens, flip latch plate over (**fig. c**) and re-buckle. Test installation again to see if lap belt stays tight. If not, move car seat to another seating location.

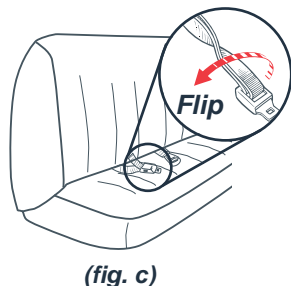

## Lap Belts - With Retractor

---

Lap belts with retractors (**fig. d**) may or may not hold a car seat securely.

Follow these steps to determine if you have a retractor system that will hold car seat securely:

- Pull belt all the way out.
- Allow belt to retract about 6 inches (15 cm).
- Pull out on belt again.

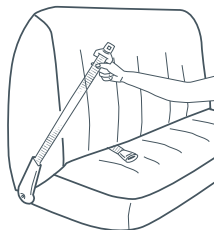

(fig. d)

If belt is locked and you cannot pull the belt out any further, you have an Automatic Locking Retractor which may be used with a car seat. Remember, when installing a car seat, pull belt all the way out, buckle belt, and then tighten.

If the belt pulls out (step c), the retractor is an Emergency Locking Retractor which must not be used with a car seat.

## Passive Restraints

---

### Lap Belt with Motorized Shoulder Belt (fig. e)

**DO NOT** use with any car seat.

See your vehicle dealer for options for securing a child restraint in this location.

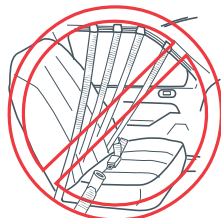

(fig. e)

## Passive Restraints

---

### Lap or Shoulder Belt Mounted on Front Door (fig. f)

**DO NOT** use with any car seat. Belts will not stay tight while driving.

See your vehicle dealer for options for securing a child restraint in this location.

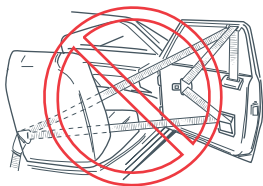

(fig. f)

### Combination Lap/Shoulder Belt with Free Sliding Latch Plate

---

Pull out on latch plate. If belt slides freely through latch plate (**fig. g**), a belt lock-off **MUST** be used.

- For rear-facing, use the blue rear-facing belt lock-off (**fig. h**) to secure the lap belt. See “Rear-facing Belt Lock-off” section.
- For forward-facing, use the red shoulder belt lock-off on the car seat to secure the lap and shoulder belt.

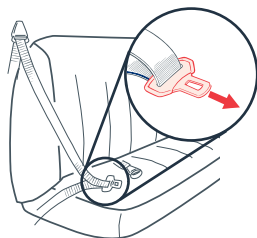

(fig. g)

Some combination lap/shoulder belts with free sliding latch plates may be converted into an “automatic locking mode”. Always use a belt lock-off with these belt systems.



(fig. h)

## Combination Lap/Shoulder Belt with Locking Latch Plate

---

Vehicle seat belts with locking latch plates (**fig. j**) normally hold a car seat tightly. However in some cases, the locking latch plate on some seat belts may slip and loosen after being buckled on car seat if positioned at a certain angle. If this happens, flip the latch plate over and re-buckle. Test installation again to see if this works. If not, move car seat to another seating location.

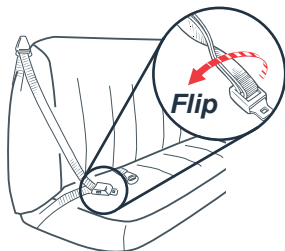

(fig. j)

## Rear-facing Belt Lock-off

**⚠ WARNING** - DEATH or SERIOUS INJURY can occur

**Avoid serious injury or death:**

- Failure to use the rear-facing belt lock-off where required will result in car seat not being securely held in place.
- Remove rear-facing belt lock-off from vehicle seat belts when not being used with car seat.

Rear-facing belt lock-off (*fig. a*) is used for rear-facing installation when using a lap and shoulder belt with sliding latch plate.



(*fig. a*)

Rear-facing belt lock-off is stored in pocket on back of seat pad.

- 1 Install car seat rear-facing on vehicle seat.
- 2 Route lap belt through rear-facing belt path. See “Rear-facing Installation With Vehicle Seat Belt” section.
- 3 Open rear-facing belt lock-off. Rotate locking tab down ① and lift lock-off cover ② (*fig. b*).



(*fig. b*)

- 4 With arrow facing towards vehicle latch plate, position rear-facing belt lock-off around shoulder belt, close cover over shoulder belt ① and lock in place by rotating locking tab up ② (*fig. c*).
- 5 Slide belt lock-off down shoulder belt until it contacts the vehicle latch plate.
- 6 Press down in center of car seat to depress the vehicle cushion and tighten the lap belt by pulling on the shoulder belt.
- 7 While holding the lap and shoulder belt tight, slide the rear-facing belt lock-off down the shoulder belt until it is tight against the vehicle latch plate.
- 8 Test installation to see if car seat is secure.



If not secure:

- Try tightening lap belt again.
- Try a different seating position or DO NOT use this car seat.

When not using rear-facing belt lock-off, store in pocket on back of seat pad.

## Section 15 - Additional Information

### Certification

---

This car seat meets or exceeds all applicable requirements of Federal Motor Vehicle Safety Standard 213 for use in motor vehicles.

### Aircraft Use

---

**This restraint is Certified for Use in Motor Vehicles and Aircraft (see label on car seat).**

Contact airline about their policy on use of child restraints on the Aircraft.

Use this car seat only on forward-facing aircraft seats.

Install car seat on aircraft the same way it is installed in a vehicle.

### Warm Weather

---

Car seat parts can get very hot in the sun or warm weather.

***To avoid burns, always check before putting child in car seat.***

### Vehicle Seat Protection

---

Protect vehicle seat. Use a thin car seat mat, thin towel or thin blanket under and behind car seat.

### Car Seat Useful Life

---

DO NOT use after 7 years from date of manufacture on label.

### Instruction Manual Storage

---

Store instruction manual in pocket at top of seat back.



## Section 16 - Care And Cleaning

### **Remove Seat Pad and Infant Insert:**

- Remove infant insert, see “Infant Insert” section.
- Remove harness straps from seat pad, see “Changing Shoulder Harness Position” section.
- Remove seat pad - unsnap harness adjustment strap from front of pad, unhook pad retainers on each side and at front of car seat and lift pad off seat back and seat bottom.

Reverse above steps for replacing seat pad and harness system.

### **Cleaning Seat Pad and Infant Insert Pad:**

Infant Insert - Remove foam pads from seat insert.

Machine wash in cool water and mild soap. Roll in towel to remove excess water and lay flat to dry.

### **Cleaning Harness Straps:**

Surface wash only with mild soap and damp cloth.

If harness straps are frayed or heavily soiled, they **MUST** be replaced.

### **Cleaning Shell:**

Wipe with mild solution of soap and water. Avoid wetting labels.

Never use “household detergents”: they can weaken plastic.

### **Cleaning Buckle:**

Rinse buckle with warm water. **DO NOT** use household detergents.

Never lubricate buckle.

## Section 17 - Registration Information

Child restraints (car seats) could be recalled for safety reasons. You must register this restraint to be reached in a recall. Fill out the registration card or send your name, address, and the restraint's model number and manufacturing date to:

Combi USA, Inc.  
3520 Westinghouse Blvd., Suite B  
Charlotte, NC 28273

or call Toll Free: 1-800-992-6624

or register online at

[http://www.Combi-intl.com/car\\_reg.html](http://www.Combi-intl.com/car_reg.html)

or fax 1-704-697-1695

or log onto [www.CombiUSA.com](http://www.CombiUSA.com)

For recall information:

- Call the U.S Government's Vehicle Safety Hotline at 1-888-327-4236 (TTY: 1-800-424-9153) or go to <http://www.NHTSA.gov>
- Log onto the National Highway Traffic Safety Administration recall website at [www.safercar.gov](http://www.safercar.gov) and follow links to Child Restraint Recalls.

## Section 18 - Re-use After A Crash

### **WARNING** - DEATH or SERIOUS INJURY can occur

- **DO NOT allow any re-use of this car seat after a crash unless crash and car seat meet ALL conditions in “Re-use After A Crash” section of this manual. Do not sell or allow others to use a car seat that has been in a crash and does not comply with ALL of these conditions.**

Car seats are damaged in vehicle crashes and in many cases, the car seat must be destroyed and replaced. However, the National Highway Traffic Safety Administration (NHTSA) advises that if a child restraint (car seat) has been used in a minor crash that the child restraint can continue to be used with your child.

For information on car seat re-use after a crash, check the NHTSA website at:  
[www.nhtsa.gov/people/injury/childps/ChildRestraints/ReUse/RestraintReUse.htm](http://www.nhtsa.gov/people/injury/childps/ChildRestraints/ReUse/RestraintReUse.htm).

Damage to car seats may be difficult to see or it may be difficult to verify the damage to the car seat. For those situations where any of the NHTSA Child Restraint Re-use criteria has not been met, or if there is uncertainty whether damage to the seat has occurred, NHTSA and Combi USA advise parents or caregivers to contact their automobile insurance company regarding its policy on replacement of seats.

DO NOT risk your child's safety.

## Section 19 - Limited Warranty

1. Combi products, when purchased from an authorized retailer, are warranted to the original purchaser to be free of defect in materials and workmanship for a period of one (1) year from date of purchase. Warranty is valid for products purchased and used in the U.S. only and used in compliance with the warrantor's use and maintenance instructions. Save your carton and receipt in case return for warranty service is necessary.
2. During the warranty period your Combi product will either be repaired or replaced, at the warrantor's discretion, without charge if it is purchased from an authorized Combi dealer and is found to be defective in workmanship or materials. For service call 1-800-99-COMBI (1-800-992-6624). The warrantor shall not be responsible for any costs incurred by the consumer in returning a defective product for repair.

This limited warranty shall not apply to normal wear to the product, or if the product has been:

- a. Damaged due to accidents, misuse, abuse or neglect as determined by Combi.
- b. Tampered with or repaired by other than an authorized Combi repair center or with parts other than Combi approved parts.
- c. Leased or rented for commercial use.

THE WARRANTY PROVIDED HEREIN IS EXCLUSIVE AND IS IN LIEU OF ALL OTHER EXPRESS WARRANTIES. ANY IMPLIED WARRANTIES, INCLUDING ANY IMPLIED WARRANTY OF MERCHANTABILITY OR FITNESS FOR A PARTICULAR PURPOSE ARE EXPRESSLY EXCLUDED. WARRANTOR'S OBLIGATIONS AND THE CONSUMER'S OR OTHER BUYERS REMEDIES UNDER THE LIMITED WARRANTY ABOVE ARE EXCLUSIVE AND ARE STRICTLY LIMITED TO REPAIR OR REPLACEMENT AS STATED. ANY INCIDENTAL OR CONSEQUENTIAL DAMAGES ON THE PART OF THE WARRANTOR AND ANY SUPPLIER OR DEALER ARE HERBY ALSO EXPRESSLY EXCLUDED.

Some states limit or do not allow exclusions or limitations on how long an implied warranty lasts so the above limitations may not apply to you. Some states do not allow the exclusion or limitations of incidental or consequential damages, so the above limitations or exclusion may not apply to you. This warranty gives you specific legal rights, and you may also have other rights which vary from state to state.





# Combi®

**Storage  
Pocket**

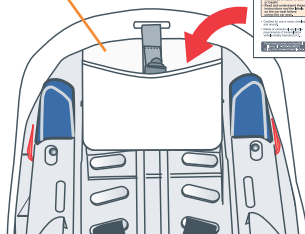

Keep this instruction manual for future use.  
Store instruction manual in pocket on top of seat back.

© 2011 Combi USA, Inc.

CCS0210G - 06/11

**Combi USA, Inc.**

- 3520 Westinghouse Blvd., Suite B • Charlotte, NC 28273
- For technical questions, call 1-800-992-6624
- Fax 1-704-697-1695 • [www.CombiUSA.com](http://www.CombiUSA.com)