

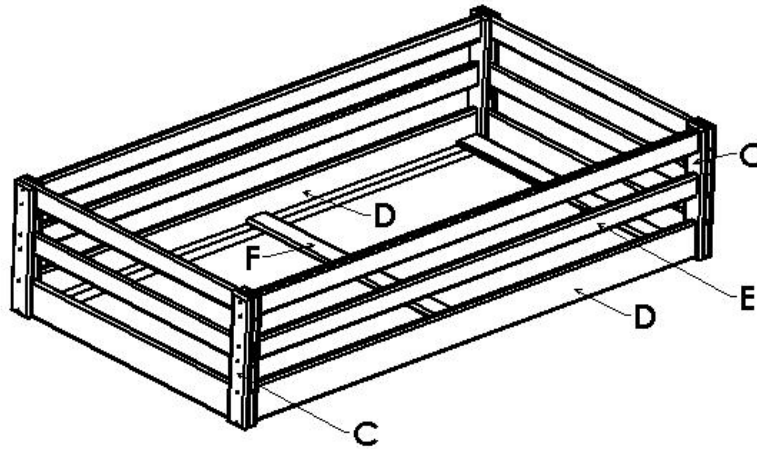

4875/4876

7030-00435

**COASTER TETON**  
**LOFT TOP BUNK**



**PARTS LIST:**

- A) 24 -4 1/4" Lag Bolts
- B) 24 -Black Steel Washers
- C) 2 -End Assemblies
- D) 2 -5 1/4" x 75" Mattress Rails w/Support Cleats
- E) 4 -3 1/4" x 75" Guard Rails
- F) 3 -3 1/2" x 38 1/2" Mattress Supports
- G) 14 -1 1/4" Black Flat Head Wood Screws
- H) 8 -Angle Brackets
- I) 32-3/4" Round Head Screws
- J) 2 -Modular Roundup Case Ends (Desk or Chest)

**TOOLS REQUIRED:**

- 1) 7/16" Wrench or Socket Wrench
- 2) Phillips Head Screwdriver

**NOTE: Tool recommended: Electric driver with 7/16" socket**

**ASSEMBLY INSTRUCTIONS:**

**NOTE:**

**Make sure you have all parts before beginning assembly. If you need a part, contact the dealer where you purchased your bed.**

- 1) Attach two mattress rails(D) and guardrails(E) to end assemblies(C) with 24 lag bolts and 24 washers, and tighten.
- 2) Place modular case ends(K) as pictured on other side, with an overall width of approximately 84". Place completed top bed assembly on the ends. There should be about 3" of each modular end top extending beyond the bed assembly at each end.
- 3) Refer to other side
- 4) **Place 3 mattress supports on mattress rail support cleats, with one support in the center, and a support pushed tightly against each end assembly.**
- 6) **Secure mattress supports with 6 wood screws.**
- 7) Add a bunk board or slat kit and the proper thickness innerspring bunk mattress. See dealer for details.
- 8) Attach ladder as described in ladder instructions.

- 9) Fasten the bed assembly to the modular ends with 8 angle brackets(H), placing brackets as shown below. Secure brackets with 32 screws(I).

