



4877

COASTER TETON BED

with CASTERS 4877/4878

00430

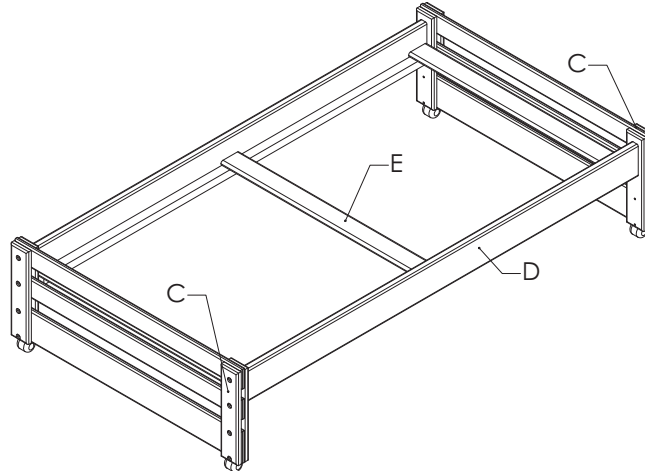

PARTS LIST:

- A) 8 -4 1/4" Lag Bolts
- B) 8 -Black Steel Washers
- C) 2 -End Assemblies
- D) 2 -5 1/4" x 75" Mattress Rails w/Support Cleats
- E) 3 -3 1/2" x 38 1/2" Mattress Supports
- F) 6 -1 1/4" Wood Screws
- G) 4 -Casters with inserts

***NOTE: CASTERS HAVE INSERTS WHICH MUST BE DRIVEN FLUSH WITH THE HOLES DRILLED, BEFORE THE CASTERS ARE INSERTED. ATTEMPTING TO DRIVE THE INSERTS IN WITH THE CASTER WHEELS MAY RESULT IN DAMAGE TO THE WHEELS

TOOLS REQUIRED:

- 1) 7/16" Wrench or Socket Wrench
- 2) Phillips Head Screwdriver

NOTE: Tool recommended: Electric driver with 7/16" socket

ASSEMBLY INSTRUCTIONS:

NOTE:

Make sure you have all parts before beginning assembly. If you need a part, contact the dealer where you purchased your bed.

- 1) Attach two mattress rails (D) to end assemblies(C) with 8 lag bolts and 8 washers, and tighten. The height of the mattress rails is adjustable.
- 2) **Place 3 mattress supports on mattress rail support cleats, with one support in the center, and a support pushed tightly against each end assembly.**
- 3) **Secure mattress supports with 6 wood screws.**
- 4) Seat caster inserts fully in bottom of end assemblies, and snap casters in place.
- 5) Add a bunk board or slat kit and the proper thickness innerspring bunk mattress. (See dealer for details)